

## LCD Bias Solution with Level Shifters for GOA Panels

Check for Samples: [TPS65155](#)

### FEATURES

- 3 V to 6 V Input Voltage Range
- Boost Converter With 4 A Switch Current Limit
- Boost Converter Output Voltages up to 18 V
- Boost Converter Overvoltage Protection
- Selectable Switching Frequency (640 kHz or 1.2 MHz)
- Programmable Boost Converter Soft-Start
- Temperature-Compensated Positive Charge Pump Controller
- Negative Charge Pump Controller
- 4 + 2 Channels of Level Shifters
- $\overline{\text{XAO}}$  Reset Signal
- Thermal Shutdown
- 40-Pin 5×5 mm QFN Package

### APPLICATIONS

- LCD Monitors or Notebook Panels using GOA Technology

### DESCRIPTION

The TPS65155 provides an integrated bias and level shifter solution for GOA panels.

The device integrates a boost converter to generate the source driver supply voltage ( $V_{\text{AVDD}}$ ), positive and negative charge pump controllers to generate gate driver ON ( $V_{\text{GH}}$ ) and OFF ( $V_{\text{GL}}$ ) voltages, and an 6-channel level shifter in a single IC. The positive charge pump controller supports temperature compensation to reduce  $V_{\text{GH}}$  at high temperatures.

In addition to the above functions, the TPS65155 generates an additional active-low  $\overline{\text{XAO}}$  reset output.

Supply sequencing during power-up can be controlled by an externally generated enable signal.

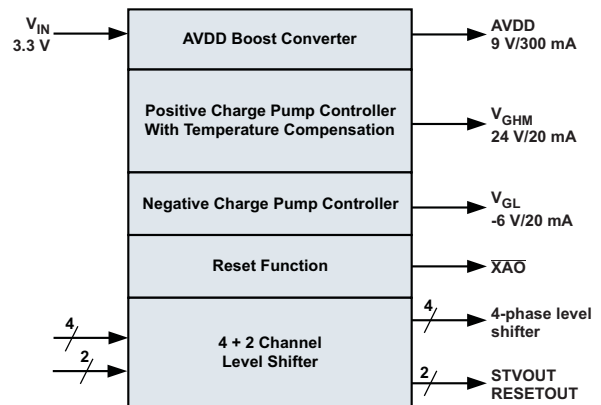

Please be aware that an important notice concerning availability, standard warranty, and use in critical applications of Texas Instruments semiconductor products and disclaimers thereto appears at the end of this data sheet.



These devices have limited built-in ESD protection. The leads should be shorted together or the device placed in conductive foam during storage or handling to prevent electrostatic damage to the MOS gates.

### ORDERING INFORMATION<sup>(1)</sup>

T <sub>A</sub>	ORDERING	PACKAGE	PACKAGE MARKING
–40°C to 85°C	TPS65155RKPR	40-Pin 5×5 QFN	TPS65155

(1) The device is supplied taped and reeled, with 3000 devices per reel.

### ABSOLUTE MAXIMUM RATINGS

over operating free-air temperature range (unless otherwise noted) <sup>(1)</sup>

		VALUE	UNIT
Pin Voltage <sup>(2)</sup>	FBN, VREF, SCL, SDA, FBP, RESETIN, CLKIN1, CLKIN2, CLKIN3, CLKIN4, FBPH, FREQ, COMP, FB, SS, VIN, DRVN, VDET, STVIN, RNTC, EN, XA0	7	V
	AVDD, SW	20	
	DRV_P, VGH	40	
	VGL	–20	
	STVOUT, RESETOUT, CLKOUT1, CLKOUT2, CLKOUT3, CLKOUT4	–20 to 40	
ESD Rating	Human Body Model	2	kV
	Machine Model	200	V
	Charged Device Model	500	V
P <sub>D</sub>	Continuous Power Dissipation	See Thermal Table	W
T <sub>A</sub>	Ambient temperature	–40 to 85	°C
T <sub>J</sub>	Junction temperature	–40 to 150	°C
T <sub>STG</sub>	Storage temperature	–65 to 150	°C
	Lead temperature (soldering, 10 seconds)	300	°C

- (1) Stresses beyond those listed under “absolute maximum ratings” may cause permanent damage to the device. These are stress ratings only and functional operation of the device at these or any other conditions beyond those indicated under “recommended operating conditions” is not implied. Exposure to absolute-maximum-rated conditions for extended periods may affect device reliability.
- (2) With respect to the AGND and LGND pins.

### THERMAL INFORMATION

THERMAL METRIC <sup>(1)</sup>		TPS65155	UNITS
		QFN	
		40 PINS	
θ <sub>JA</sub>	Junction-to-ambient thermal resistance	36.1	°C/W
θ <sub>JC(top)</sub>	Junction-to-case(top) thermal resistance	30.0	
θ <sub>JB</sub>	Junction-to-board thermal resistance	10.5	
ψ <sub>JT</sub>	Junction-to-top characterization parameter	0.7	
ψ <sub>JB</sub>	Junction-to-board characterization parameter	10.5	
θ <sub>JC(bottom)</sub>	Junction-to-case(bottom) thermal resistance	4.6	

(1) For more information about traditional and new thermal metrics, see the *IC Package Thermal Metrics* application report, [SPRA953](#).

**RECOMMENDED OPERATING CONDITIONS**

		MIN	TYP	MAX	UNIT
$V_{IN}$	Input voltage range	3	5	6	V
$V_{AVDD}$	Boost converter output voltage range	7 <sup>(1)</sup>		18	V
$V_{GH}$	Level shifter positive supply voltage range	15		38	V
$V_{GL}$	Level shifter negative supply voltage range	-3		-15	V
$V_{DET}$	Panel discharge threshold voltage	2			V
$C_{REF}$	$V_{REF}$ decoupling capacitance	10	100	220	nF
$T_A$	Operating ambient temperature	-40	25	85	°C
$T_J$	Operating junction temperature	-40	85	125	°C

(1) Or  $V_{IN} + 1$  V, whichever is lower.

**ELECTRICAL CHARACTERISTICS**

$V_{IN} = 5$  V;  $V_{AVDD} = 13.6$  V,  $V_{GH} = 28$  V,  $V_{GL1} = V_{GL2} = -10$  V,  $T_A = -40$ °C to 85°C; FREQ = high. Typical values are at 25°C (unless otherwise noted).

PARAMETER	TEST CONDITIONS	MIN	TYP	MAX	UNIT		
<b>POWER SUPPLY</b>							
$I_{IN}$	$V_{IN}$ supply current	Device not switching, $V_{FB} = V_L + 5\%$		0.75	mA		
$I_{SUP}$	Positive supply current			0.04	mA		
$I_{GH}$	Positive supply current	STVIN = 0 V, RESETIN = 0 V, CLKIN1-CLKIN4 = 0 V		0.26	mA		
$I_{GL}$	Negative supply current	STVIN = 0 V, RESETIN = 0 V, CLKIN1-CLKIN4 = 0 V		0.035	mA		
$V_{UVLO}$	UVLO threshold	$V_{IN}$ rising		2.5	V		
$V_{HYS}$	UVLO hysteresis	$V_{IN}$ falling		0.25	V		
$V_{REF}$	External reference voltage	$I_L = 100$ $\mu$ A		1.215	1.24	1.265	V
$I_{REF}$	Reference voltage maximum output current	$V_L = 1.24$ V $\pm$ 2%		250		$\mu$ A	
<b>CONTROL SIGNALS (EN, FREQ)</b>							
$V_{IH}$	High input voltage threshold	EN, FREQ rising			2.0	V	
$V_{IL}$	Low input voltage threshold	EN, FREQ falling		0.5		V	
$R_{PULL-UP}$	Pull-up resistor	EN, FREQ			50	k $\Omega$	
<b>RESET (<math>\overline{XAO}</math>)</b>							
$V_{OL}$	Low level output voltage	$I_{\overline{XAO}} = 1$ mA, sinking			0.5	V	
$I_{OH}$	High level leakage current	$V_{\overline{XAO}} = 5$ V			2	$\mu$ A	

**ELECTRICAL CHARACTERISTICS (continued)**

$V_{IN} = 5\text{ V}$ ;  $V_{AVDD} = 13.6\text{ V}$ ,  $V_{GH} = 28\text{ V}$ ,  $V_{GL1} = V_{GL2} = -10\text{ V}$ ,  $T_A = -40^\circ\text{C}$  to  $85^\circ\text{C}$ ; FREQ = high. Typical values are at  $25^\circ\text{C}$  (unless otherwise noted).

PARAMETER		TEST CONDITIONS	MIN	TYP	MAX	UNIT
<b>BOOST CONVERTER (AVDD)</b>						
$V_{AVDD}$	Output voltage	$I_{AVDD} = 0.5\text{ A}$	7		18 <sup>(1)</sup>	V
$V_{OVP}$	Overshoot threshold	$V_{AVDD}$ rising	18.0	19.0	20.0	V
$V_{OVP(HYS)}$	Overshoot hysteresis	$V_{AVDD}$ falling		0.3		V
$V_{SCP(AVDD)}$	Short-circuit threshold voltage	$V_{AVDD}$ rising, during power-up		2.6		V
		$V_{FB}$ falling, during normal operation		0.36		
$V_{FB(PG)}$	Power good threshold	$V_{FB}$ rising		97		% of $V_{REF}$
		$V_{FB}$ falling		91.7		
$t_{SCP(AVDD)}$	Short circuit timer	OFF time		55		ms
		ON time		15		
$V_{FB}$	Feedback regulation voltage		1.228	1.240	1.252	V
$I_{FB}$	Feedback input bias current	$V_{FB} = 1.24\text{ V}$	-100		100	nA
$g_m$	Error amplifier transconductance		80		140	$\mu\text{A/V}$
$r_{DS(ON)}$	Switch ON resistance	$V_{IN} = 5\text{ V}$ , $I_{SW} = I_{LIM}$		0.13	0.18	$\Omega$
$I_{LIM}$	Switch current limit		4.0	4.8	5.6	A
$I_{LK}$	Switch leakage current	$EN = 0\text{ V}$ , $V_{SW} = 18.5\text{ V}$			30	$\mu\text{A}$
$I_{SS}$	Soft-start capacitor charge current	$V_{SS} = 1.24\text{ V}$		4.4		$\mu\text{A}$
$f_{SW}$	Oscillator frequency	FREQ connected to $V_{IN}$	900	1200	1500	kHz
		FREQ connected to 0V	470	640	790	
	Line regulation	$V_{IN} = 4\text{ V}$ to $6\text{ V}$ , $I_{AVDD} = 0.5\text{ A}$		0.01		%/V
	Load regulation	$I_{AVDD} = 0.1\text{ A}$ to $0.5\text{ A}$		0.2		%/A
<b>POSITIVE CHARGE PUMP CONTROLLER (VGH)</b>						
$V_{DRVP}$	Base drive voltage range	With external pull-up resistor			40	V
$I_{DRVP}$	Base drive sink current	Normal operation, sinking, $V_{FBP} = 1.575\text{ V}$ , $V_{DRVP} = 28\text{ V}$	2.5			mA
		Short-circuit operation, sinking, $V_{FBP} = 0\text{ V}$ , $V_{DRVP} = 28\text{ V}$	40		72	$\mu\text{A}$
$V_{FBP}$	Feedback regulation voltage	Lower limit; $V_{RNTC} = 2\text{ V}$ , $V_{FBPH} = 1.75\text{ V}$	1.663	1.75	1.838	V
		Lower limit; $V_{RNTC} = 1.5\text{ V}$ , $V_{FBPH} = 1.75\text{ V}$	1.425	1.50	1.575	
		Lower limit; $V_{RNTC} = 1.0\text{ V}$ , $V_{FBPH} = 1.75\text{ V}$	1.178	1.24	1.302	
$V_{FBP(SCP)}$	Short circuit threshold voltage	$V_{FBP}$ rising, during power-up		124		mV
		$V_{FBP}$ falling, during normal operation		340		
$V_{FBP(PG)}$	Power good threshold	$V_{FBP}$ rising		97.5		% of $V_{REF}$
		$V_{FBP}$ falling		92.5		
$t_{SCP(VGH)}$	Short circuit timer	Starts from boost converter power good		15		ms
$I_{FBP}$	FBP input bias current	$V_{RNTC} = 1\text{ V}$ , $V_{FBPH} = 1.75\text{ V}$ , $V_{FBP} = 1.24\text{ V}$	-100		100	nA
$I_{RNTC}$	RNTC output current	$V_{RNTC} = 1.5\text{ V}$ , matched to $I_{FBPH}$ ; at $T_A = 25^\circ\text{C}$	190	200	210	$\mu\text{A}$
$I_{FBPH}$	FBPH output current	$V_{FBPH} = 1.75\text{ V}$ , trimmed; at $T_A = 25^\circ\text{C}$	195	200	205	$\mu\text{A}$
	Load regulation	$I_{GH} = 1\text{ mA}$ to $50\text{ mA}$		0.05		%/mA

(1) Limited by overvoltage protection function.

**ELECTRICAL CHARACTERISTICS (continued)**

$V_{IN} = 5\text{ V}$ ;  $V_{AVDD} = 13.6\text{ V}$ ,  $V_{GH} = 28\text{ V}$ ,  $V_{GL1} = V_{GL2} = -10\text{ V}$ ,  $T_A = -40^\circ\text{C}$  to  $85^\circ\text{C}$ ; FREQ = high. Typical values are at  $25^\circ\text{C}$  (unless otherwise noted).

PARAMETER		TEST CONDITIONS	MIN	TYP	MAX	UNIT
<b>NEGATIVE CHARGE PUMP CONTROLLER (VGL)</b>						
$I_{DRVN}$	Base drive current	Normal operation, sourcing, $V_{FBN} = 25\text{ mV}$ , $V_{DRVN} = 0.7\text{V}$	2.5			mA
		Short-circuit operation, sourcing, $V_{FBN} = 1.116\text{ V}$ , $V_{DRVN} = 0.7\text{ V}$	200	300	480	$\mu\text{A}$
$V_{FBN}$	Feedback regulation voltage	$I_{DRVN} = 1\text{ mA}$ , sourcing	-15		15	mV
$I_{FBN}$	FBN input bias current	$V_{FBN} = 0\text{ V}$	-100		100	nA
$V_{FBN(SCP)}$	Short circuit threshold voltage	$V_{FBN}$ falling, during start-up		794		mV
		$V_{FBN}$ rising, during normal operation		817		
$V_{FBN(PG)}$	Power good threshold	$V_{FBN}$ falling		2.8		% of $V_{REF}$
		$V_{FBN}$ rising		7.5		
$t_{SCP(VGL)}$	Short circuit timer	Starts from boost converter power good		15		ms
	Load regulation	$I_{GL1} = 1\text{ mA}$ to $50\text{ mA}$		0.05		%/mA
<b>LEVEL SHIFTERS (CLK1 to CLK4)</b>						
$V_{UVLO}$	UVLO threshold	$V_{GH}$ rising.	5.0	7.5	10.0	V
$V_{IH}$	Level shifter high level input threshold	$V_{CLKINx}$ rising			1.5	V
$V_{IL}$	Level shifter low level input threshold	$V_{CLKINx}$ falling	0.5			V
$r_{DS(ON)}$	High side ON resistance	$I_{CLKOUTx} = 10\text{ mA}$ , sourcing		14		$\Omega$
	Low side ON resistance	$I_{CLKOUTx} = 10\text{ mA}$ , sinking		8		
<b>LEVEL SHIFTERS (STV, RESET)</b>						
$V_{IH}$	Level shifter high level input threshold	$V_{STVIN}$ , $V_{RESETIN}$ rising			1.5	V
$V_{IL}$	Level shifter low level input threshold	$V_{STVIN}$ , $V_{RESETIN}$ falling	0.5			V
$r_{DS(ON)}$	High side ON resistance	$I_{STVOUT}$ , $I_{RESETOUT} = 10\text{ mA}$ , sourcing		35		$\Omega$
	Low side ON resistance	$I_{STVOUT}$ , $I_{RESETOUT} = 10\text{ mA}$ , sinking		15		
<b>I<sup>2</sup>C INTERFACE</b>						
	Bus address			4Fh		
$V_{IL}$	Low level input voltage	$V_{IN} = 4\text{ V}$ to $6\text{ V}$	0.7			V
$V_{IH}$	High level input voltage	$V_{IN} = 4\text{ V}$ to $6\text{ V}$			1.5	V
$V_{OL}$	Low level output voltage	Sinking $3\text{ mA}$			0.4	V
<b>THERMAL SHUTDOWN</b>						
$T_{SD}$	Thermal shutdown threshold			138		$^\circ\text{C}$
$T_{HYS}$	Thermal shutdown hysteresis			8		$^\circ\text{C}$



**PIN FUNCTIONS**

PIN		I/O	DESCRIPTION
NAME	NO.		
COMP	1	I	Boost converter compensation
AGND	2	P	Analog ground
SS	3	I	Boost converter soft-start capacitor connection
NC	4	O	No connection. Leave the pin floating
FB	5	I	Boost converter feedback
PGND	6	P	Power ground
SW	7	P	Boost converter switch node
FREQ	8	I	Boost converter frequency select
VIN	9	P	Supply voltage
/XAO	10	O	Reset
EN	11	I	Device enable
VDET	12	I	Panel discharge input
GND	13	I	Ground
AVDD	14	P	High voltage analog supply
GND	15	I	Ground
SCL	16	I/O	I <sup>2</sup> C interface clock
SDA	17	I/O	I <sup>2</sup> C interface data
LGND	18	P	Level shifter ground connection
CLKOUT1	19	O	Level shifter input
CLKOUT2	20	O	Level shifter input
CLKOUT3	21	O	Level shifter input
CLKOUT4	22	O	Level shifter input
STVOUT	23	O	Level shifter input
RESETOUT	24	O	Level shifter input
NC	25		No connection. Leave this pin floating.
RESETIN	26	I	Level shifter input
STVIN	27	I	Level shifter input
CLKIN4	28	I	Level shifter input
CLKIN3	29	I	Level shifter input
CLKIN2	30	I	Level shifter input
CLKIN1	31	I	Level shifter input
VGH	32	P	Level shifter positive supply
VGL	33	P	Level shifter negative supply
FBN	34	I	Negative charge pump regulator feedback
VREF	35	O	Internal voltage reference
DRVN	36	O	Negative charge pump regulator drive signal (connects to base of external NPN transistor)
FBP	37	I	Positive charge pump regulator feedback
DRVP	38	O	Positive charge pump regulator drive signal (connects to base of external PNP transistor)
RNTC	39	I	Positive charge pump LDO thermistor connection
FBPH	40	I	Positive charge pump LDO temperature-setting resistor connection
ePAD		P	Exposed pad. Connect to the system GND

## TYPICAL CHARACTERISTICS

### TABLE OF GRAPHS

			FIGURE
<b>BOOST CONVERTER</b>			
Efficiency		$V_{IN} = 5\text{ V}, V_{AVDD} = 13.6\text{ V}, I_{AVDD} = 0\text{ A to }1\text{ A}$	Figure 1
		$V_{IN} = 5\text{ V}, V_{AVDD} = 18\text{ V}, I_{AVDD} = 0\text{ A to }1\text{ A}$	Figure 2
Frequency	vs Load current	$V_{IN} = 5\text{ V}, V_{AVDD} = 13.6\text{ V}, I_{AVDD} = 0\text{ A to }0.8\text{ A}$	Figure 3
	vs Supply voltage	$V_{IN} = 3.5\text{ V to }6.0\text{ V}, V_{AVDD} = 13.6\text{ V}, I_{AVDD} = 0.5\text{ A}$	Figure 4
Undervoltage Protection	$f_{SW} = 1.2\text{ MHz}, L = 4.7\mu\text{H}$	$V_{IN} = 5\text{ V}, V_{AVDD} = 13.6\text{ V}$ (10 V transient)	Figure 5
Load Transient Response	$f_{SW} = 640\text{ kHz}, L = 10\mu\text{H}$	$V_{IN} = 5\text{ V}, V_{AVDD} = 13.6\text{ V}, I_{AVDD} = 250\text{ mA}/750\text{ mA step}$	Figure 6
	$f_{SW} = 1.2\text{ MHz}, L = 4.7\mu\text{H}$		Figure 7
Soft-start	$C_{SS} = 22\text{ nF}$	$V_{IN} = 5\text{ V}, V_{AVDD} = 13.6\text{ V}, I_{AVDD} = 0.5\text{ A}$	Figure 8
Overshoot Protection	Duration = 75 ms		Figure 9
Short-Circuit Protection	Duration = 75 ms	$V_{IN} = 5\text{ V}, V_{AVDD} = 13.6\text{ V}, I_{AVDD} = 0.5\text{ A}$	Figure 10
	Duration = 25 ms	$V_{IN} = 5\text{ V}, V_{AVDD} = 13.6\text{ V}, I_{AVDD} = 0.5\text{ A}$	Figure 11
Switch Node Waveform	CCM operation	$V_{IN} = 5\text{ V}, V_{AVDD} = 13.6\text{ V}, I_{AVDD} = 0.5\text{ A}$	Figure 12
	DCM operation	$V_{IN} = 5\text{ V}, V_{AVDD} = 13.6\text{ V}, I_{AVDD} = 0.1\text{ A}$	Figure 13
<b>POSITIVE CHARGE PUMP</b>			
Load Transient Response	$f_{SW} = 640\text{ kHz}, L = 10\mu\text{H}$	$V_{IN} = 5\text{ V}, V_{AVDD} = 13.6\text{ V}, I_{AVDD} = 0.5\text{ A}, V_{GH} = 28\text{ V}, I_{GL} = 10\text{ mA}/50\text{ mA step}$	Figure 14
	$f_{SW} = 1.2\text{ MHz}, L = 4.7\mu\text{H}$		Figure 15
Temperature Compensation		$V_{IN} = 4\text{ V to }6\text{ V}, V_{AVDD} = 13.6\text{ V}, I_{AVDD} = 0.5\text{ A}, V_{GH(COLD)} = 28\text{ V}, V_{GH(HOT)} = 24\text{ V}, T_{COLD} = -10^\circ\text{C}, T_{HOT} = 10^\circ\text{C}, I_{GL} = 25\text{ mA}$	Figure 16
<b>NEGATIVE CHARGE PUMP</b>			
Load Transient Response	$f_{SW} = 640\text{ kHz}, L = 10\mu\text{H}$	$V_{IN} = 5\text{ V}, V_{AVDD} = 13.6\text{ V}, I_{AVDD} = 0.5\text{ A}, V_{GL} = -10\text{ V}, I_{GL} = 10\text{ mA}/50\text{ mA step}$	Figure 17
	$f_{SW} = 1.2\text{ MHz}, L = 4.7\mu\text{H}$		Figure 18
<b>START-UP SEQUENCING</b>			
Power-Up Sequence	$V_{IN}, V_{AVDD}, V_{GH}, V_{GL}$	$V_{IN} = 5\text{ V}, V_{AVDD} = 13.6\text{ V}, V_{GH} = 28\text{ V}, V_{GL} = -10\text{ V}$	Figure 19
Power-Up Sequence	$V_{IN}, \text{CLKOUTx}, \text{STVOUT}, \text{RESETOUT}$	$V_{IN} = 5\text{ V}, V_{AVDD} = 13.6\text{ V}, V_{GH} = 28\text{ V}, V_{GL} = -10\text{ V}$	Figure 20
Power-Down Sequence	$V_{IN}, \text{CLKOUTx}, \text{STVOUT}, \text{RESETOUT}$	$V_{IN} = 5\text{ V}, V_{AVDD} = 13.6\text{ V}, V_{GH} = 28\text{ V}, V_{GL} = -10\text{ V}$	Figure 21
<b>LEVEL SHIFTERS</b>			
Peak Output Current	CLKOUTx	$V_{GH} = 28\text{ V}, V_{GL} = -10\text{ V}, 10\text{ nF load}$	Figure 22
	STVOUT, RESETOUT		Figure 23
Rise Time	CLKOUTx	$V_{GH} = 28\text{ V}, V_{GL} = -10\text{ V}, 47\Omega + 10\text{ nF load}$	Figure 24
	STVOUT, RESETOUT		Figure 25
Fall Time	CLKOUTx	$V_{GH} = 28\text{ V}, V_{GL} = -10\text{ V}, 47\Omega + 10\text{ nF load}$	Figure 26
	STVOUT, RESETOUT		Figure 27

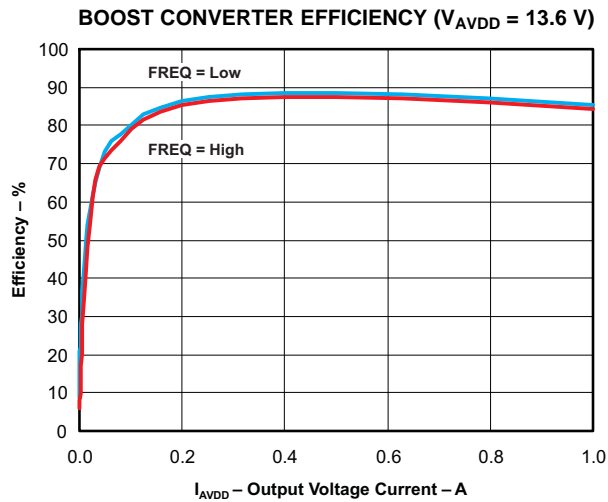

Figure 1.

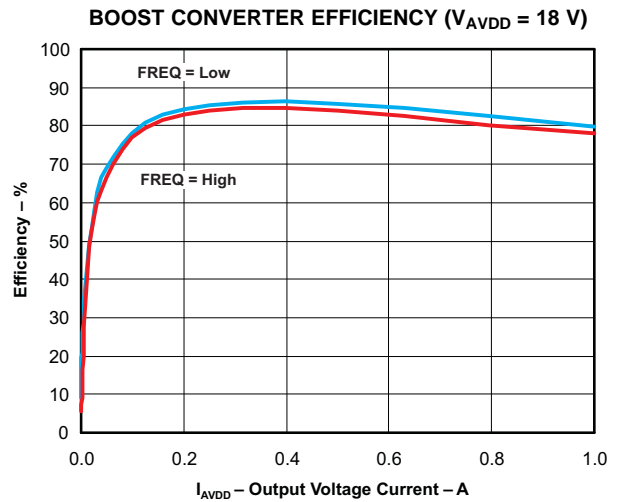

Figure 2.

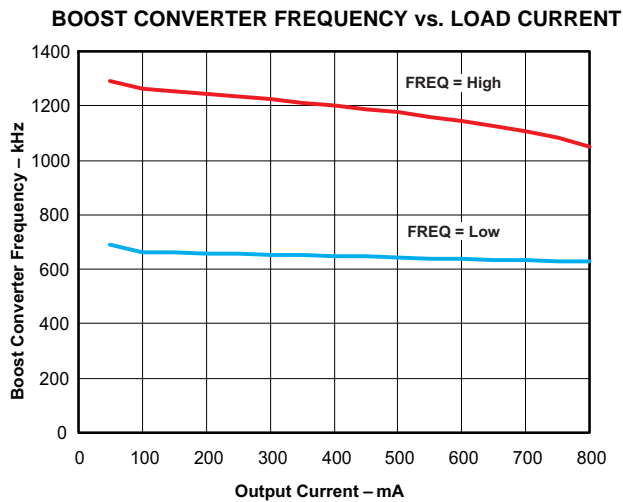

Figure 3.

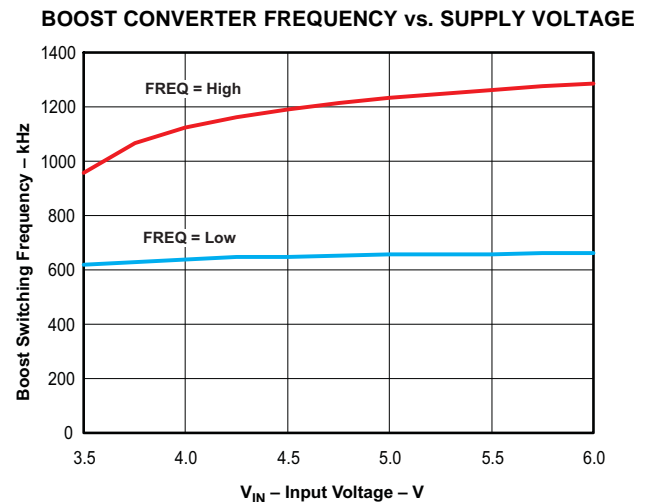

Figure 4.

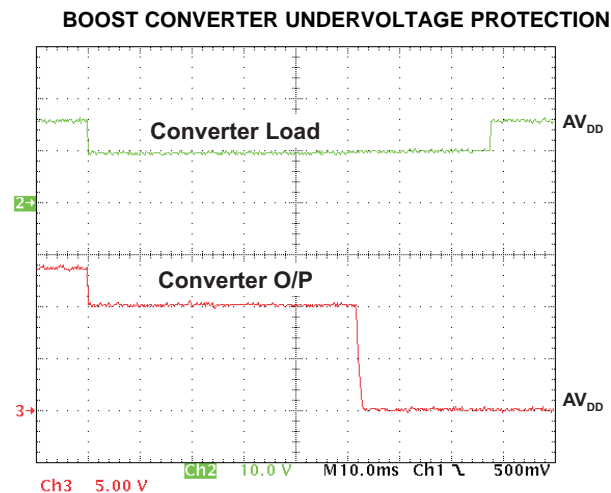

Figure 5.

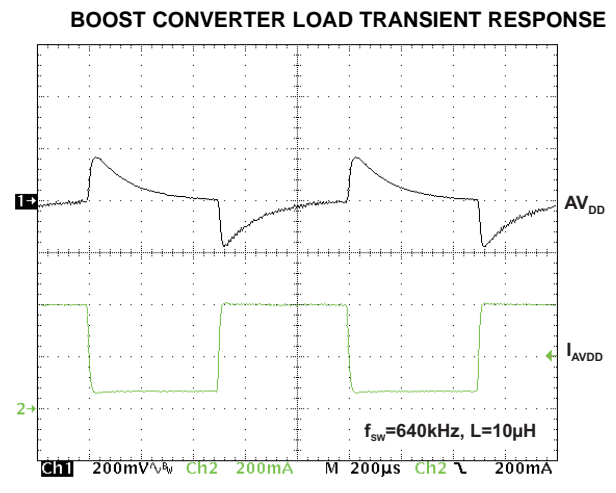

Figure 6.

**BOOST CONVERTER LOAD TRANSIENT RESPONSE**

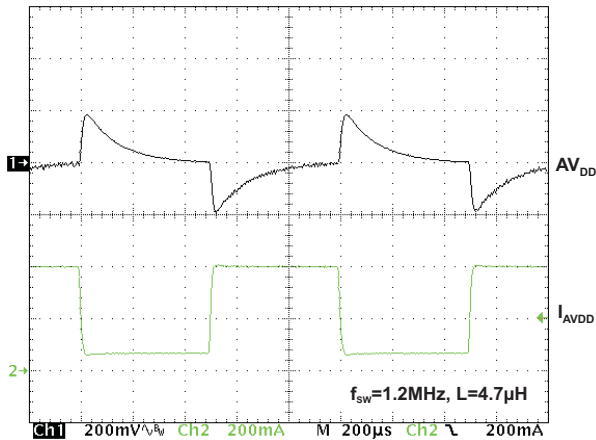

Figure 7.

**BOOST CONVERTER SOFT-START**

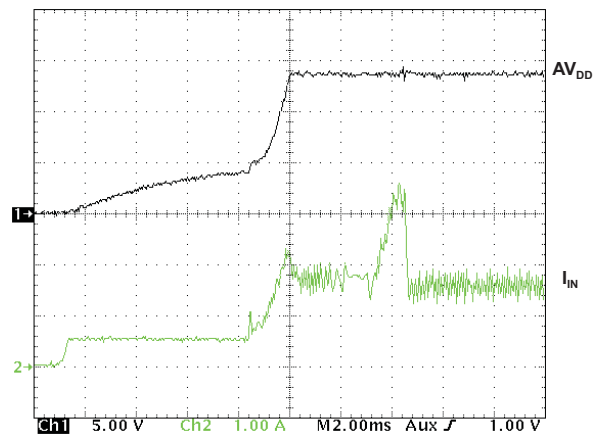

Figure 8.

**BOOST CONVERTER OVERVOLTAGE PROTECTION**

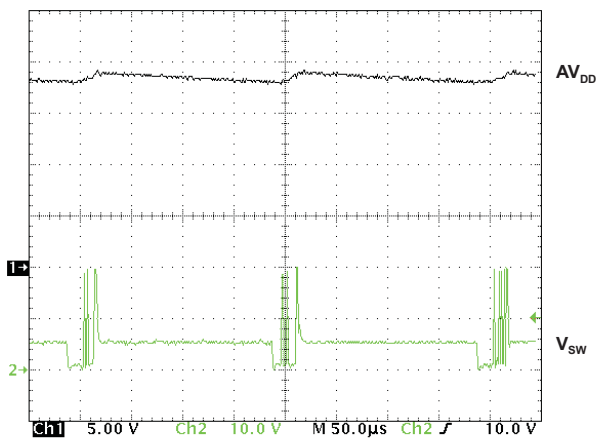

Figure 9.

**BOOST CONVERTER SHORT-CIRCUIT PROTECTION**

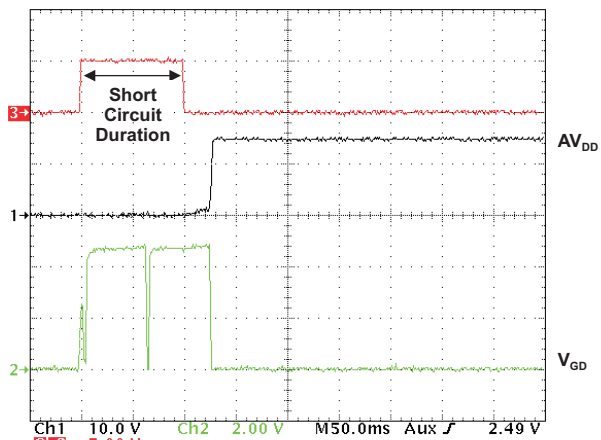

Figure 10.

**BOOST CONVERTER SHORT-CIRCUIT PROTECTION**

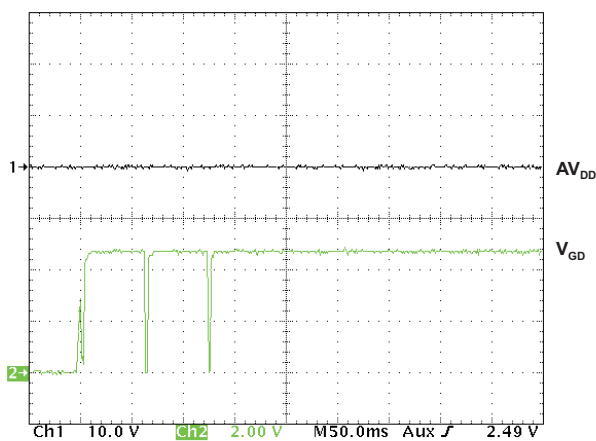

Figure 11.

**BOOST CONVERTER SWITCH NODE WAVEFORM (CCM)**

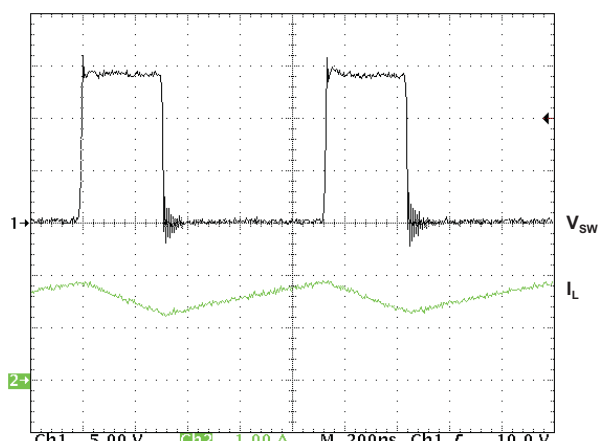

Figure 12.

BOOST CONVERTER SWITCH NODE WAVEFORM (DCM)

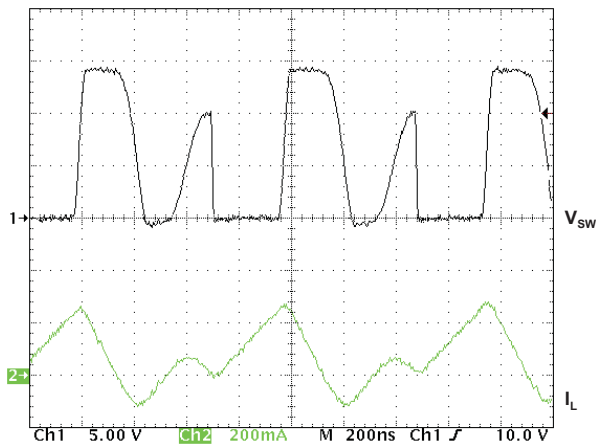

Figure 13.

POSITIVE CHARGE PUMP LOAD TRANSIENT RESPONSE

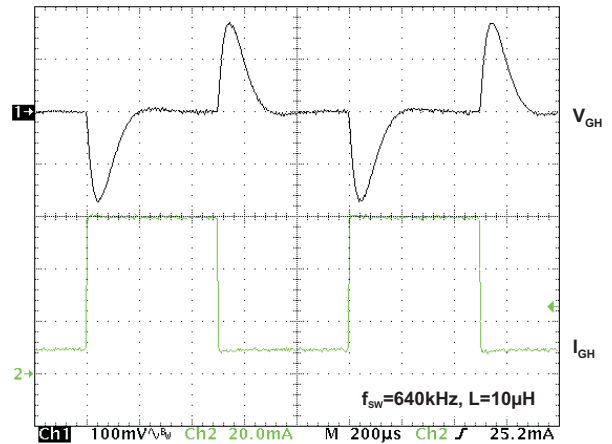

Figure 14.

POSITIVE CHARGE PUMP LOAD TRANSIENT RESPONSE

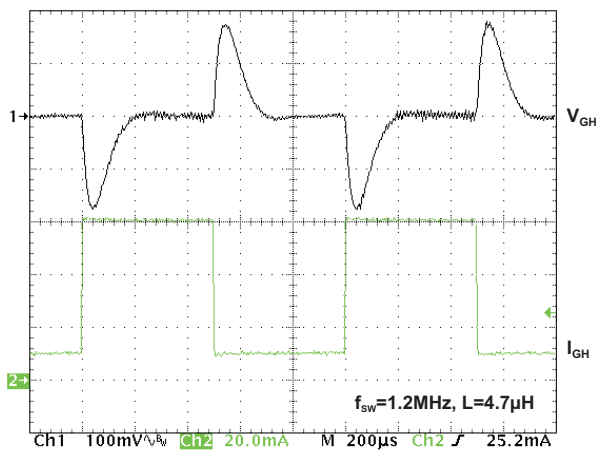

Figure 15.

POSITIVE CHARGE PUMP TEMPERATURE COMPENSATION

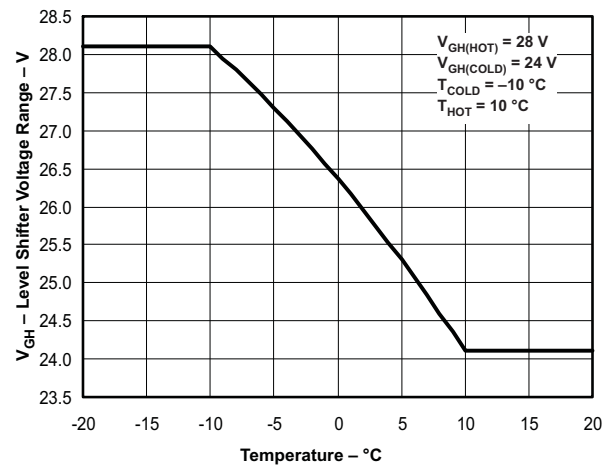

Figure 16.

NEGATIVE CHARGE PUMP LOAD TRANSIENT RESPONSE

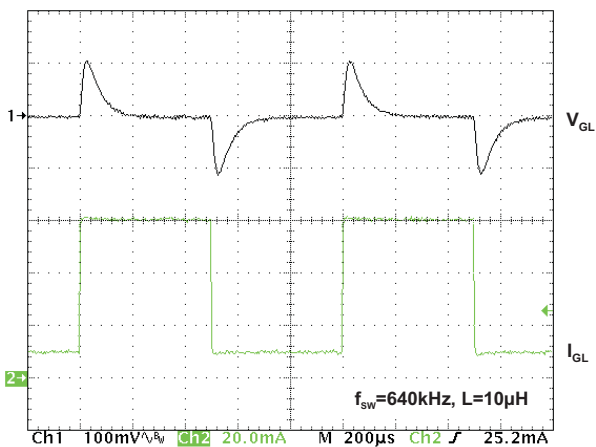

Figure 17.

NEGATIVE CHARGE PUMP LOAD TRANSIENT RESPONSE

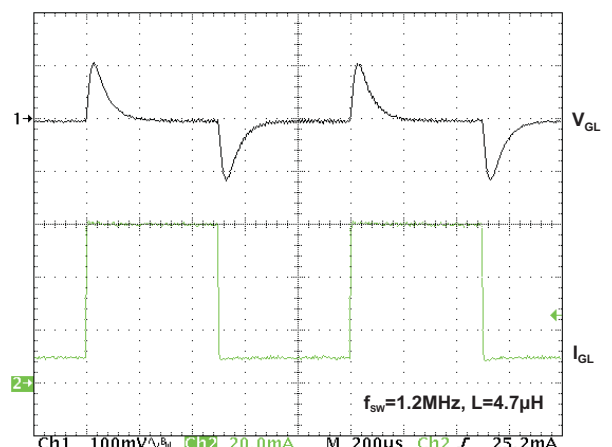

Figure 18.

POWER-UP SEQUENCE #1

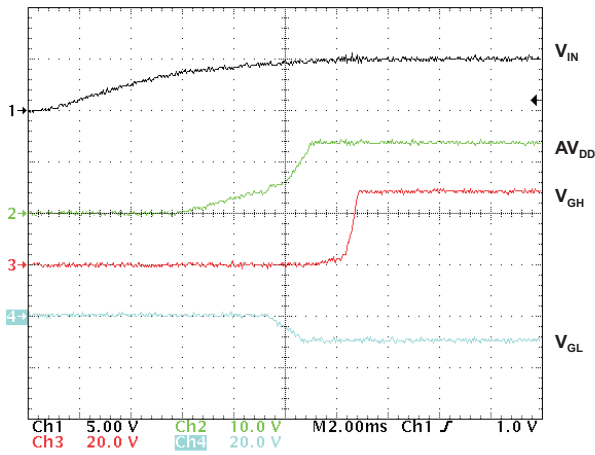

Figure 19.

POWER-UP SEQUENCE #2

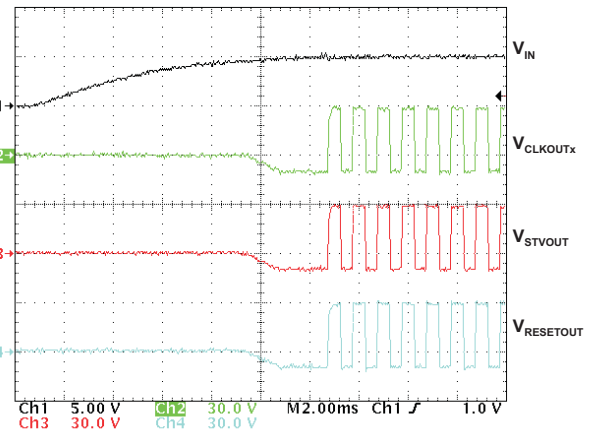

Figure 20.

POWER-DOWN SEQUENCE #1

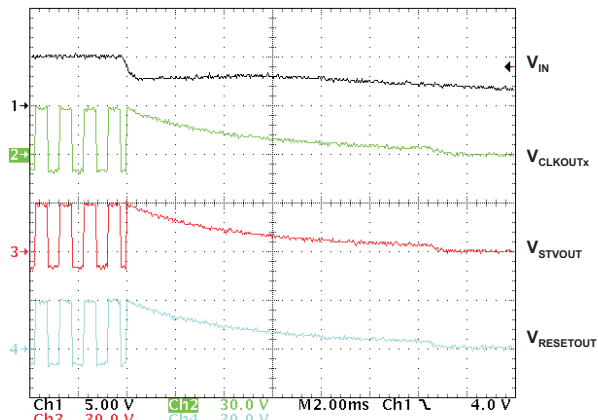

Figure 21.

PEAK OUTPUT CURRENT (CLKx)

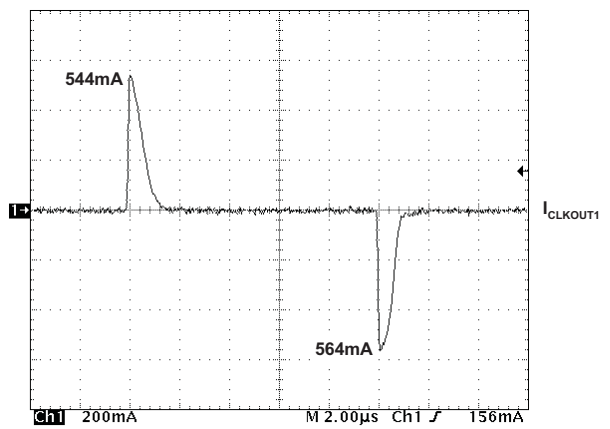

Figure 22.

PEAK OUTPUT CURRENT (STVOUT, RESETOUT)

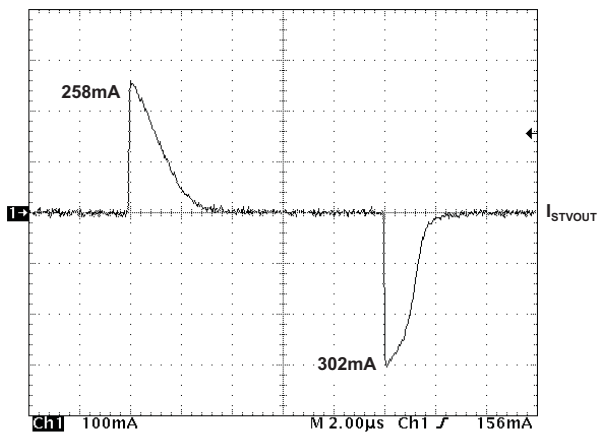

Figure 23.

RISE TIME (CLKOUTx)

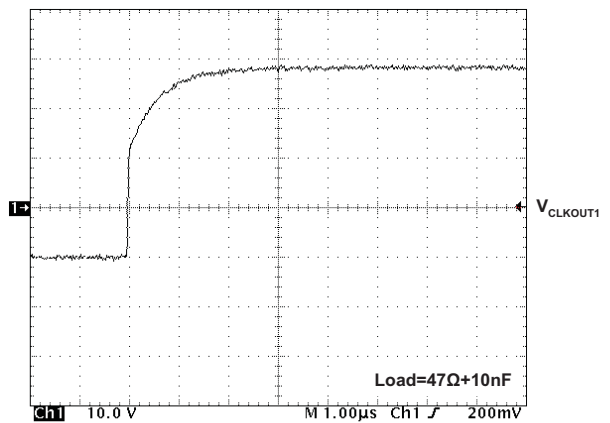

Figure 24.

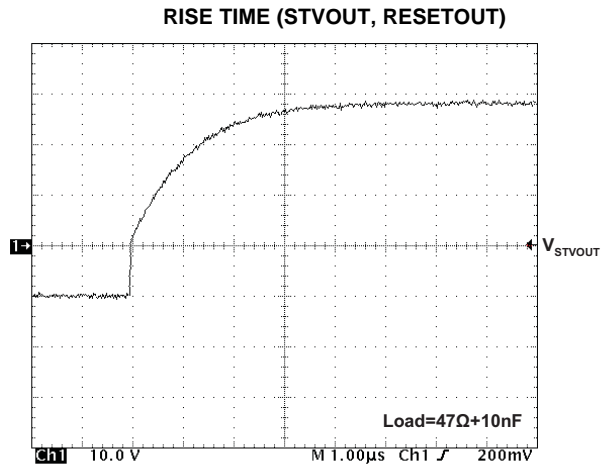

Figure 25.

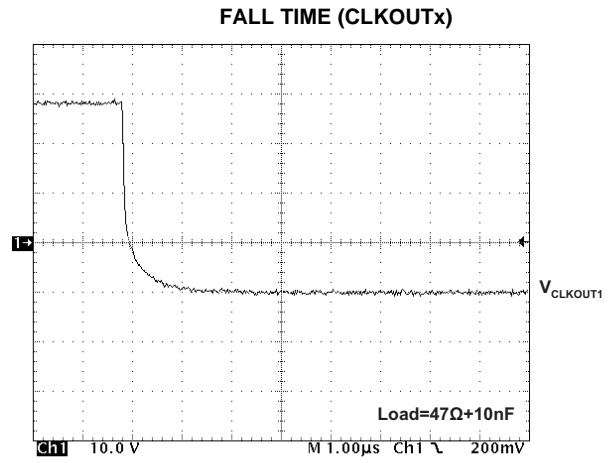

Figure 26.

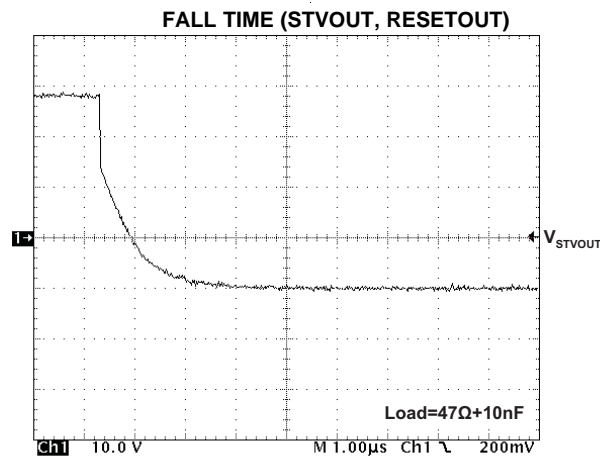

Figure 27.

DETAILED DESCRIPTION

An internal block diagram of the TPS65155 is shown in Figure 28.

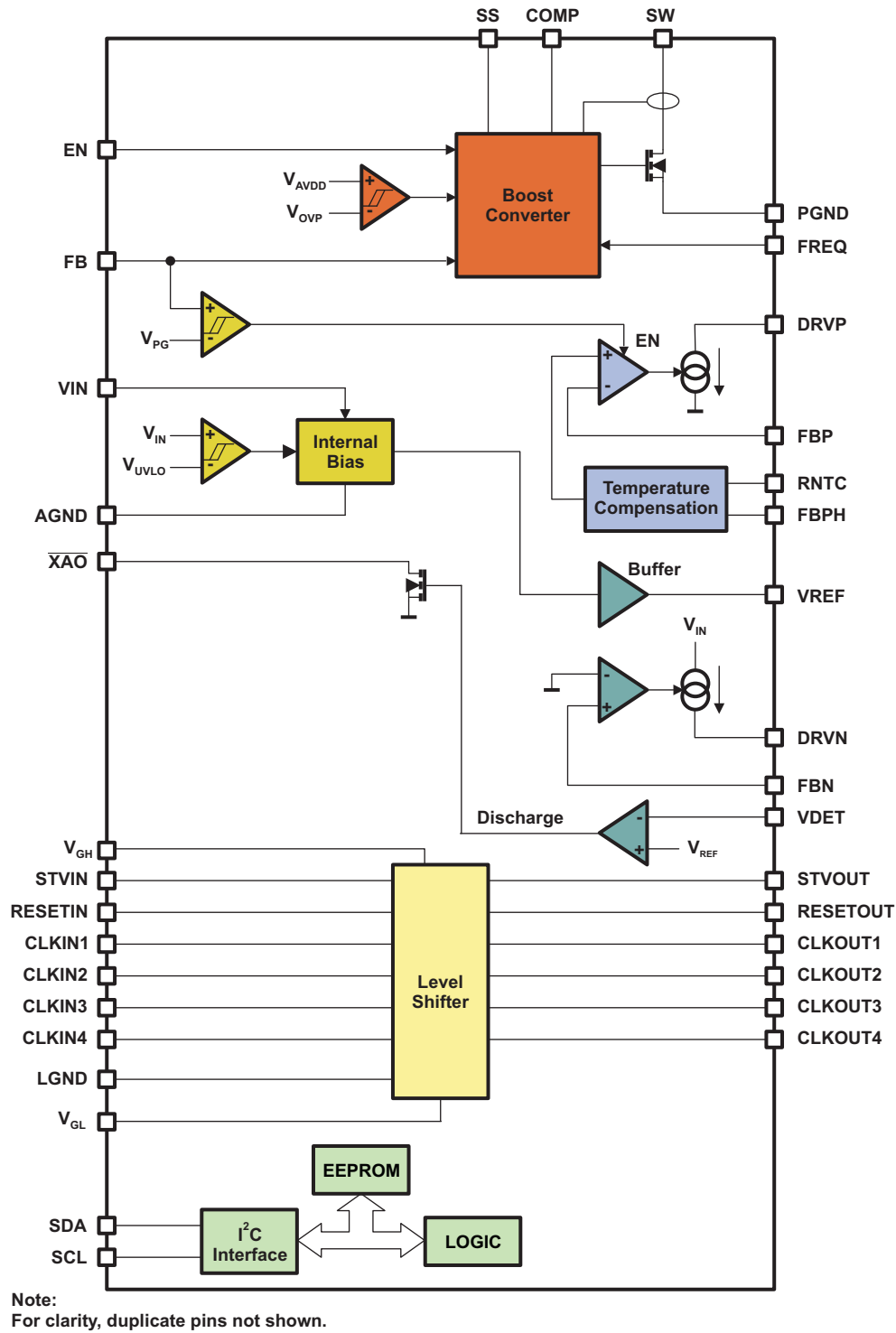

Figure 28. Internal Block Diagram

## Boost Converter

An internal block diagram of the boost converter is contained in [Figure 29](#).

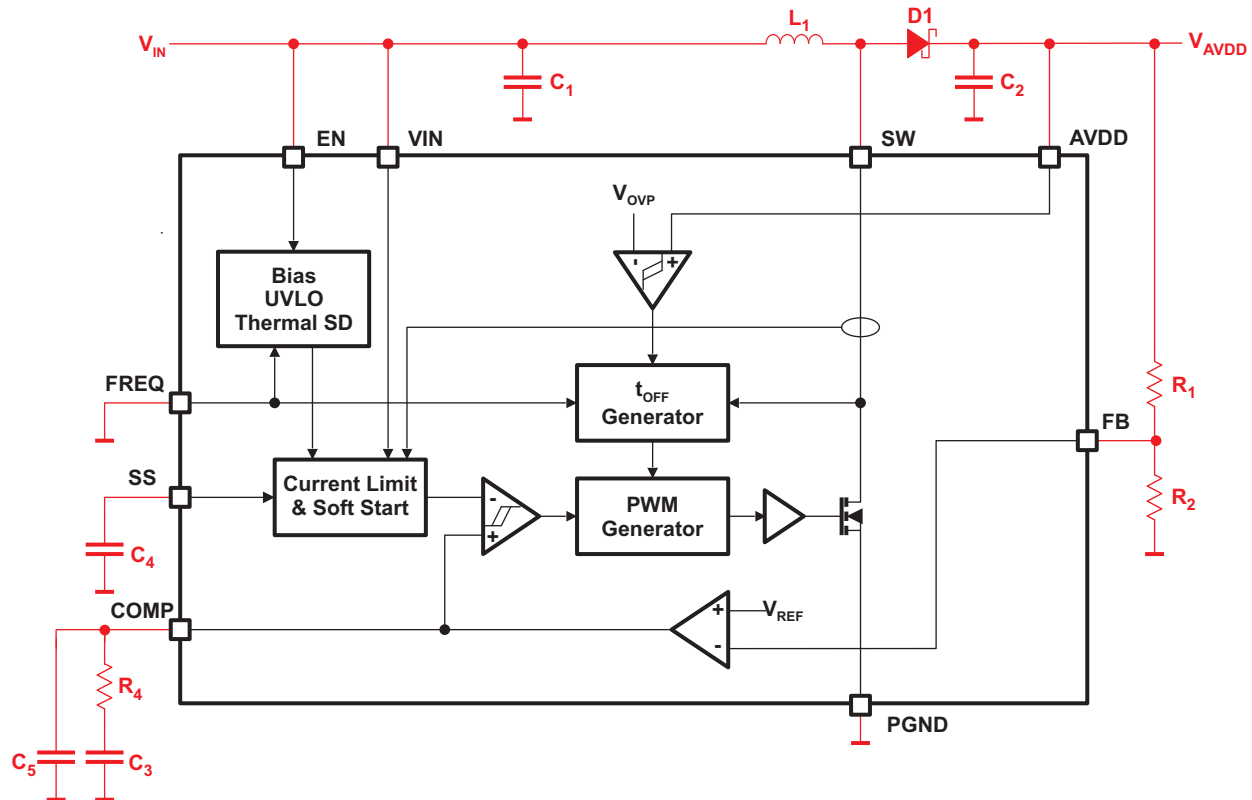

Figure 29. Boost Converter Internal Block Diagram

The boost converter is designed for output voltages up to 18V with a switch current limit of 4 A (guaranteed minimum). The converter uses a current mode, quasi-constant frequency topology, and is externally compensated for maximum flexibility. A soft-start feature limits the current drawn from  $V_{IN}$  during start-up, and the converter's switching frequency can be selected between 640 kHz and 1.2 MHz.

The converter's adaptive off-time topology achieves superior transient response and operates over a wider range of applications than conventional converters.

### Design Procedure (Boost Converter)

The first step in the design procedure is to calculate the peak switch current. The simplest way to do this is to use the curves in the typical characteristics section to estimate converter efficiency in the intended application. Alternatively, a conservative worst-case value such as 85% can be used.

Once a value for the converter's efficiency  $\eta$  is available, [Equation 1](#) can be used to calculate its duty cycle.

$$D = 1 - \frac{V_{IN} \times \eta}{V_{AVDD}} \quad (1)$$

The next step is to use [Equation 2](#) to calculate the change in inductor current per cycle.

$$\Delta I_L = \frac{V_{IN} \times D}{f \times L} \quad (2)$$

Finally, the peak switch current can be calculated using [Equation 3](#).

$$I_{SW(PK)} = \frac{I_{AVDD}}{1 - D} + \frac{\Delta I_L}{2} \quad (3)$$

The value for peak switch current calculated using [Equation 3](#) must be lower than the minimum specified for the device, and should be calculated under worst-case conditions (minimum  $V_{IN}$  and maximum  $I_{AVDD}$ ).

### Inductor Selection (Boost Converter)

The boost converter in the TPS65155 has been optimized for inductors in the range 3.3  $\mu\text{H}$  to 6.8  $\mu\text{H}$  when using the higher switching frequency and in the range 7  $\mu\text{H}$  to 13  $\mu\text{H}$  when using the lower switching frequency.

The saturation current of the inductor must be greater than the peak switch current plus an additional margin to allow for heavy load transients. A saturation current of 130% of the value calculated using [Equation 3](#) is adequate for most applications.

[Table 1](#) shows a selection of inductors suitable for use with the TPS65155.

**Table 1. Boost Converter Inductor Selection**

INDUCTANCE	MANUFACTURER	PART NUMBER	SIZE	DCR	ISAT
<b>1.2 MHz OPERATION</b>					
4.7 $\mu\text{H}$	Coiltronics	UP2B-4R7-R	14.0 × 10.4 × 6.0	17 m $\Omega$	5.5 A
4.7 $\mu\text{H}$	Sumida	CDRH12NP-4R7-M	12.3 × 12.3 × 4.5	18 m $\Omega$	5.7 A
4.7 $\mu\text{H}$	Sumida	CDRH127	12.3 × 12.3 × 8.0	12 m $\Omega$	6.8 A
<b>640 kHz OPERATION</b>					
10 $\mu\text{H}$	Coilcraft	DS3316P	13.0 × 9.4 × 5.1	70 m $\Omega$	3.5 A
10 $\mu\text{H}$	Sumida	CDRH8D43	8.3 × 8.3 × 4.5	29 m $\Omega$	4.0 A
10 $\mu\text{H}$	Sumida	CDRH127	12.3 × 12.3 × 8.0	16 m $\Omega$	5.4 A
10 $\mu\text{H}$	Sumida	CDRH127LD	12.3 × 12.3 × 8.0	15 m $\Omega$	6.7 A

### Rectifier Selection (Boost Converter)

A Schottky type is recommended for the boost converter rectifier diode because its low forward voltage improves efficiency. The diode's reverse voltage rating must be greater than 20 V, which is the maximum it will experience (the TPS65155's overvoltage protection function prevents this voltage being any higher). The diode's average rectified current rating must be at least as high as the maximum  $I_{AVDD}$ . A 2 A rating is sufficient for most applications.

[Equation 4](#) can be used to calculate the power dissipated in the diode. The diode must be capable of handling this power without overheating. A power rating of 500 mW is sufficient for most applications.

$$P = V_F \times I_{AVDD} \quad (4)$$

Where:

$V_F$  is the diode's forward voltage

$I_{AVDD}$  is the average (mean) boost converter output current

[Table 2](#) shows a selection of rectifier diodes suitable for use with the TPS65155.

**Table 2. Boost Converter Rectifier Selection**

CURRENT	MANUFACTURER	PART NUMBER	SIZE	VR	VF
2 A	Vishay	SL22	SMA	20 V	0.44 V at 2 A
2 A	Vishay	SS22	SMA	20 V	0.5 V at 2 A

### Input Capacitor Selection (Boost Converter)

For good supply voltage filtering, low ESR capacitors are recommended. The TPS65155 has an analog supply voltage pin ( $V_{IN}$ ) that should be decoupled with a ceramic capacitor in the range 100 nF to 1  $\mu\text{F}$ , connected close to the  $V_{IN}$  pin.

The main boost converter (i.e. where  $V_{IN}$  is connected to the inductor of the boost converter) should also be decoupled. Two 10  $\mu\text{F}$  or one 22  $\mu\text{F}$  ceramic capacitor are adequate for most applications, however, these values can be increased if improved filtering is required.

### Setting the Output Voltage (Boost Converter)

The output voltage of the boost converter is set by a resistor divider connected to the FB pin. The boost converter's main error amplifier compares the feedback voltage with the internal reference voltage  $V_{REF}$  so that the output is regulated at a voltage given by [Equation 5](#).

$$V_{AVDD} = 1.24 \times \left( \frac{R_1}{R_2} + 1 \right) \quad (5)$$

### Soft-Start (Boost Converter)

To reduce the inrush current drawn from  $V_{IN}$  during start-up the boost converter includes a soft-start feature. Soft-start is controlled by a capacitor connected to the soft-start (SS) pin. During soft-start, this capacitor is charged up by a current source and the voltage across the capacitor determines the switch current limit: the larger the capacitor, the slower the ramp of the switch current limit and therefore the longer the soft-start time. The maximum switch current limit is achieved when the voltage connected to the boost converter's feedback pin (FB) reaches its power good threshold (approximately 97 percent of its nominal value).

A 22 nF soft-start capacitor is suitable for most applications.

When the EN pin is pulled low, the soft-start capacitor is discharged.

### Frequency Select (FREQ)

The frequency select (FREQ) pin can be used to set the nominal boost converter switching frequency to either 640 kHz (FREQ=low) or 1.2 MHz (FREQ=high). A higher switching frequency improves the load transient response and output voltage ripple; a lower switching frequency usually improves efficiency.

A switching frequency of 1.2 MHz is recommended for most applications unless efficiency is the primary concern.

The FREQ pin features an internal pull-up resistor that ensures the higher switching frequency is used if the pin is left floating.

### Compensation (COMP)

The boost converter uses an external compensation network connected to its COMP pin to stabilize its feedback loop. The COMP pin is connected to the output of the boost converter's transconductance error amplifier, and a series resistor and capacitor connected between this pin and AGND is sufficient to achieve good performance in most applications. The capacitor primarily influences low frequency gain and the resistor primarily influences high frequency gain. Lower output voltages require higher loop gain and therefore a larger compensation capacitor.

Good starting values, which will work for most applications running from a 5 V supply voltage, are 47 k $\Omega$  and 3.3 nF.

In some applications (e.g. those using electrolytic output capacitors), it may be necessary to include a second compensation capacitor between the COMP pin and AGND. This has the effect of adding an additional pole in the feedback loop's frequency response, which can be used to cancel the zero introduced by the electrolytic output capacitor's ESR. It is recommended to include a footprint on the PCB for this optional capacitor, even if it is not used initially.

### Overvoltage Protection (Boost Converter)

The boost converter contains an overvoltage protection (OVP) feature that limits its output voltage to a safe maximum if the FB pin is floating or shorted to ground. Overvoltage conditions are detected when the voltage applied to the AVDD pin ( $V_{AVDD}$ ) exceeds the overvoltage threshold ( $V_{OVP}$ ). As soon as this happens, the boost converter switch is turned off. It remains off until  $V_{AVDD}$  falls below  $V_{OVP}$  (minus hysteresis), at which point the boost converter automatically starts switching again.

---

#### NOTE

The AVDD pin must be connected to the boost converter output for the overvoltage protection feature to operate correctly.

---

### Short-Circuit and Undervoltage Protection (Boost Converter)

During normal operation (i.e., once the boost converter has reached its power good threshold) a short circuit is detected if the feedback voltage  $V_{FB}$  falls below 30% of  $V_{REF}$ . If this happens, the boost converter is disabled. Either  $V_{IN}$  or EN must be cycled to recover normal operation.

### Undervoltage Lockout Protection (Boost Converter)

During operation, if the output of the boost converter falls below its power good threshold for longer than 55ms, the TPS65155 will detect an undervoltage condition and turn itself off.  $V_{IN}$  or EN must be cycled to recover normal operation.

### Positive Charge Pump

Figure 30 shows the internal block diagram of the positive charge pump.

The positive charge pump is driven directly from the boost converter's switch node and then post-regulated by an external PNP transistor. The controller is optimized for transistors having a DC gain ( $h_{FE}$ ) in the range 100 to 300. The positive charge pump is temperature compensated so that its output voltage decreases at high temperatures (see Figure 16).

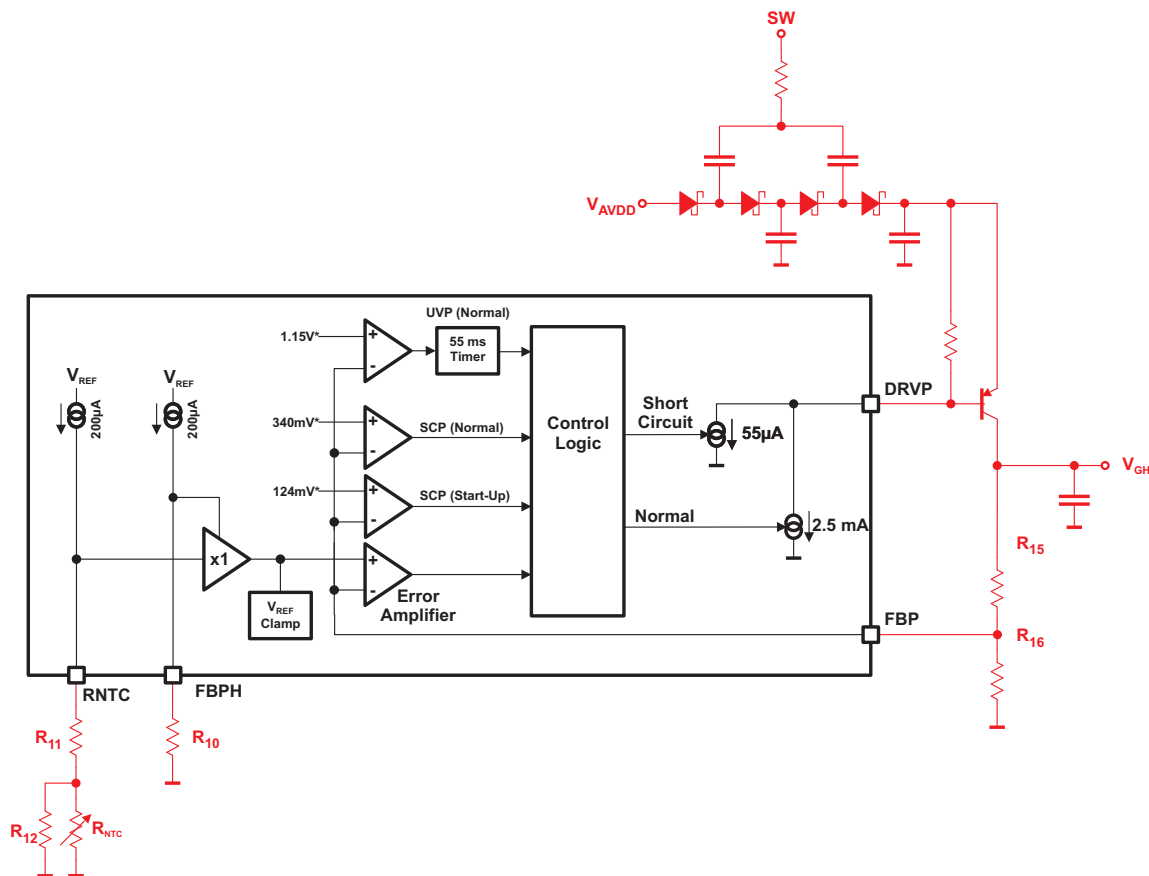

Figure 30. Positive Charge Pump Internal Block Diagram

### Setting the Output Voltage (Positive Charge Pump)

The positive charge pump in the TPS65155 is temperature compensated such that its output voltage decreases at high temperatures (see Figure 31). For a detailed description about how to set the output voltage see Temperature Compensation section below.

A current of the order of 1 mA through the feedback resistor network ensures good accuracy and increases the circuit's immunity to noise. It also ensures a minimum load on the charge pump, which reduces output voltage ripple under no-load conditions. A good approach is to assume a value of about 1.2 k for the lower resistor ( $R_{16}$ ) and then select the upper resistor ( $R_{15}$ ) to set the desired output voltage.

Note that the maximum voltage in an application is determined by the boost converter's output voltage and the voltage drop across the diodes and PNP transistor. For a typical application in which the positive charge pump is configured as a voltage doubler, the maximum output voltage is given by [Equation 6](#).

$$V_{GH(MAX)} = (2 \times V_{AVDD}) - (2 \times V_F) - V_{CE} \quad (6)$$

Where  $V_{AVDD}$  is the output voltage of the boost converter,  $V_F$  is the forward voltage of each diode and  $V_{CE}$  is the collector-emitter voltage of the PNP transistor (recommended to be at least 1 V, to avoid transistor saturation).

### Selecting the PNP Transistor (Positive Charge Pump)

The PNP transistor used to regulate  $V_{GH}$  should have a DC gain ( $h_{FE}$ ) of at least 100 when its collector current is equal to the charge pump's output current. The transistor should also be able to withstand voltages up to  $V_{GH}$  across its collector-emitter junction ( $V_{CE}$ ).

The power dissipated in the transistor is given by [Equation 7](#). The transistor must be able to dissipate this power without its junction becoming too hot. Note that the ability to dissipate power depends heavily on adequate PCB thermal design.

$$P_Q = [(2 \times V_{AVDD}) - (2 \times V_F) - V_{GH}] \times I_{GH} \quad (7)$$

Where  $I_{GH}$  is the *mean* (not RMS) output current drawn from the charge pump.

A pull-up resistor is also required between the transistor's base and emitter. The value of this resistor is not critical, but it should be large enough not to divert significant current away from the base of the transistor. A value of 100 k $\Omega$  is suitable for most applications.

### Selecting the Diodes (Positive Charge Pump)

Small-signal diodes can be used for most low current applications (<50 mA) and higher rated diodes for higher power applications. The average current through the diode is equal to the output current, so that the power dissipated in the diode is given by [Equation 8](#).

$$P_D = I_{GH} \times V_F \quad (8)$$

The peak current through the diode occurs during start-up and for a few cycles may be as high as a few amps. However, this condition typically lasts for <1 ms and can be tolerated by many diodes whose repetitive current rating is much lower. The diodes' reverse voltage rating should be equal to two times  $V_{AVDD}$ .

**Table 3. Positive Charge Pump Diode Selection**

PART NUMBER	$I_{AVG}$	$I_{PK}$	$V_R$	$V_F$	COMPONENT SUPPLIER
BAV99W	150 mA	1 A for 1 ms	75 V	1 V at 50 mA	NXP
BAT54S	200 mA	600 mA for 1s	30 V	0.8 V at 100 mA	Fairchild Semiconductor
MBR0540	500 mA	5.5 A for 8 ms	40 V	0.51 at 500 mA	Fairchild Semiconductor

### Selecting the Capacitors (Positive Charge Pump)

For lowest output voltage ripple, low-ESR ceramic capacitors are recommended. The actual value is not critical and values in the range 1  $\mu$ F to 10  $\mu$ F are suitable for most applications. Larger capacitors provide better performance in applications where large load transient currents are present.

A flying capacitor in the range 100 nF to 1  $\mu$ F is suitable for most applications. Larger values experience a smaller voltage drop by the end of each switching cycle, and allow higher output voltages and/or currents to be achieved. Smaller values tend to be physically smaller and a bit cheaper. For best performance, it is recommended to include a resistor of a few ohms (2  $\Omega$  is a good value to start with) in series with the flying capacitor to limit peak currents occurring at the instant of switching.

## Temperature Compensation (Positive Charge Pump)

The output voltage ( $V_{GH}$ ) of the positive charge pump controller is defined by two voltages and two temperatures, as illustrated in [Figure 31](#). The temperature compensation scheme is optimized for use with 10 k $\Omega$  NTC thermistors.

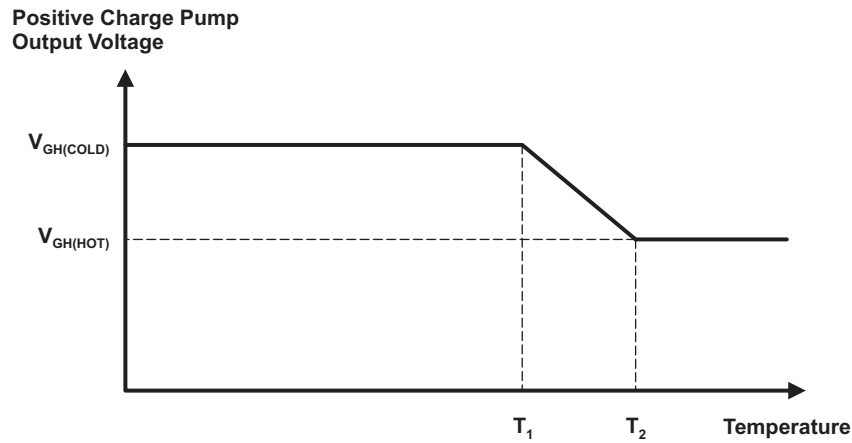

**Figure 31. Positive Charge Pump Temperature Compensation**

The error amplifier's non-inverting input, which is the reference voltage for  $V_{GH}$ , is derived from the FBPH and RNTC pins. A higher reference voltage generates a higher  $V_{GH}$ .

$V_{GH(COLD)}$  is determined by the resistor connected to the FBPH and FBP pins:

$$V_{GH(COLD)} = I_{FBPH} \times R_{10} \times \left( 1 + \frac{R_{15}}{R_{16}} \right) \quad (9)$$

$V_{GH(HOT)}$  is set by an internal clamping circuit and the resistor divider connected to the FBP pin:

$$V_{GH(HOT)} = V_{REF} \times \left( 1 + \frac{R_{15}}{R_{16}} \right) \quad (10)$$

The NTC network connected to the RNTC pin defines the temperatures  $T_1$  and  $T_2$ .

Temperature compensation can be disabled by connecting a 10 k $\Omega$  resistor between the FBPH pin and AGND and by tying the RNTC pin directly to AGND, in which case [Equation 10](#) should be used to calculate  $V_{GH}$ .

Suppose a circuit with the following characteristics is required:

## Example

A Microsoft Excel spreadsheet is available that allows easy calculation of temperature compensation components and eliminates the need for the following expressions to be calculated manually. Contact the factory to receive a free copy.

Suppose a circuit with the following characteristics is required:

$$\begin{aligned} T_1 &= 40^\circ\text{C} \\ T_2 &= 60^\circ\text{C} \\ V_{\text{GH(COLD)}} &= 28 \text{ V} \\ V_{\text{GH(HOT)}} &= 20 \text{ V} \end{aligned}$$

- The first step is to calculate the resistance of the NTC at temperatures  $T_1$  and  $T_2$   
 At temperature  $T_1$ ,  $R_{\text{NTC}(T_1)} = 5302 \ \Omega$   
 At temperature  $T_2$ ,  $R_{\text{NTC}(T_2)} = 2486 \ \Omega$

- The next step is to calculate the feedback resistors  $R_{15}$  and  $R_{16}$  as follows:

$$\frac{R_{15}}{R_{16}} = \frac{V_{\text{GH(HOT)}}}{V_{\text{REF}}} - 1$$

$$\frac{R_{15}}{R_{16}} = \frac{20\text{V}}{1.24\text{V}} - 1 = 15.13 \text{ V} \quad (11)$$

Suitable standard values from the E96 series would be  $R_{15} = 19.6 \text{ k}\Omega$  and  $R_{16} = 1.3 \text{ k}\Omega$ . With these values, the current through the feedback divider is of the order of 1mA and the nominal output voltage at high temperatures is:

$$V_{\text{GH(HOT)}} = V_{\text{REF}} \times \left( \frac{R_{15}}{R_{16}} + 1 \right)$$

$$V_{\text{GH(HOT)}} = 1.24 \text{ V} \times \left( \frac{19.6 \text{ k}\Omega}{1.3 \text{ k}\Omega} + 1 \right) = 19.94 \text{ V} \quad (12)$$

- Now calculate  $V_{\text{FBPH}}$  as follows:

$$V_{\text{FBPH}} = V_{\text{GH(HOT)}} \times \left( \frac{R_{16}}{R_{15} + R_{16}} \right)$$

$$V_{\text{FBPH}} = 28 \text{ V} \times \left( \frac{1.3 \text{ k}\Omega}{19.6 \text{ k}\Omega + 1.3 \text{ k}\Omega} \right) = 1.742 \text{ V} \quad (13)$$

The value of  $R_{10}$  required to generate  $V_{\text{FBPH}}$  can now be calculated, as follows:

$$R_{10} = \frac{V_{\text{FBPH}}}{I_{\text{FBPH}}}$$

$$R_{10} = \frac{1.742 \text{ V}}{200 \ \mu\text{A}} = 8.71 \text{ k}\Omega \quad (14)$$

Two 17.4 kΩ resistors in parallel would be suitable for R<sub>10</sub>, giving an output voltage at low temperatures given by:

$$V_{GH(COLD)} = I_{FBPH} \times R_{10} \times \left( \frac{R_{15}}{R_{16}} + 1 \right)$$

$$V_{GH(COLD)} = 200 \mu\text{A} \times \frac{17.4 \text{ k}\Omega}{2} \times \left( \frac{19.6 \text{ k}\Omega}{1.3 \text{ k}\Omega} + 1 \right) = 28.0 \text{ V} \quad (15)$$

The value of R<sub>12</sub> can be calculated by solving a standard quadratic equation:

$$R_{12} = \frac{-b \pm \sqrt{b^2 - 4 \times a \times c}}{2 \times a} \quad (16)$$

Where:

$$a = \frac{I_{SET}}{V_{FBPH} - V_{REF}} \times (R_{NTC(T1)} - R_{NTC(T2)}) - 1$$

$$a = \frac{200 \mu\text{A}}{1.74 \text{ V} - 1.24 \text{ V}} \times (5.30 \text{ k}\Omega - 2.49 \text{ k}\Omega) - 1 = 0.124$$

$$b = R_{T1} + R_{T2}$$

$$b = 5.30 \text{ k}\Omega + 2.49 \text{ k}\Omega = 7.79 \text{ k}\Omega$$

$$c = R_{T1} \times R_{T2}$$

$$c = 5.30 \text{ k}\Omega \times 2.49 \text{ k}\Omega = 13.2 \times 10^6 \Omega^2$$

Using the coefficients a, b, and c we can solve for R<sub>12</sub>:

$$R_{12} = \frac{7.79 \text{ k}\Omega + \sqrt{7.79 \text{ k}\Omega^2 + 4 \times 0.124 \times 13.2 \times 10^6 \Omega^2}}{2 \times 0.124}$$

$$R_{12} = 64.5 \text{ k}\Omega$$

A standard value of 64.9 kΩ can be used for R<sub>12</sub>.

4. The final step is to calculate the value of R<sub>11</sub> using [Equation 10](#).

$$R_{11} = \frac{V_{REF}}{I_{RNTC}} - \frac{R_{T2} \times R_{12}}{R_{T2} + R_{12}}$$

$$R_{11} = \frac{1.24 \text{ V}}{200 \mu\text{A}} - \frac{2.49 \text{ k}\Omega \times 64.9 \text{ k}\Omega}{2.49 \text{ k}\Omega + 64.9 \text{ k}\Omega} = 3.8 \text{ k}\Omega \quad (17)$$

A standard value of 3.83 kΩ can be used for R<sub>12</sub>.

[Figure 32](#) shows the temperature dependence of V<sub>GH</sub> resulting from the above calculated values.

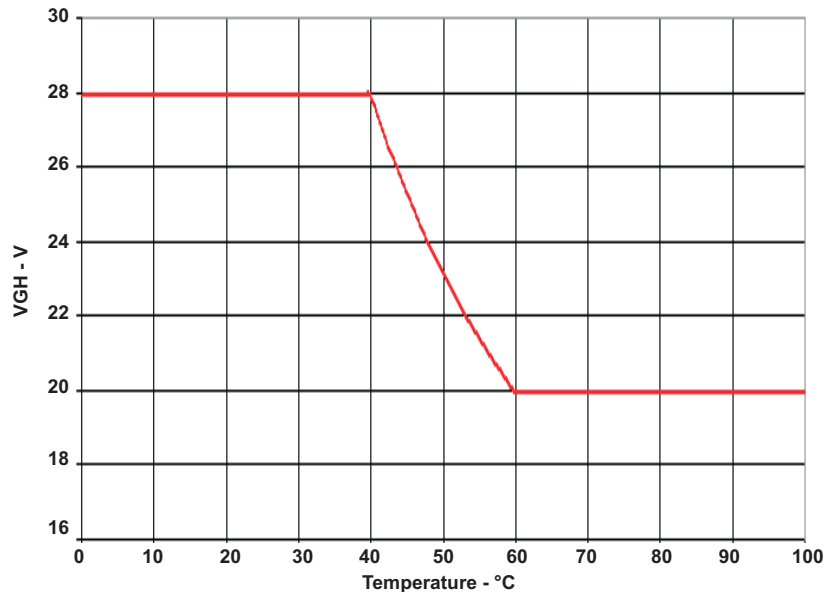

Figure 32. Temperature Compensated V<sub>GH</sub>

### Short-Circuit Protection (Positive Charge Pump)

During start-up, the positive charge pump limits the current available from V<sub>GH</sub> until V<sub>FBP</sub> > 124 mV. If V<sub>FBP</sub> is still less than 124 mV after 15 ms, the boost converter, and positive and negative charge pumps are disabled. Either V<sub>IN</sub> or EN must be cycled to recover normal operation.

During normal operation (i.e. once the positive charge pump has reached its power good threshold) short circuits are detected if V<sub>FBP</sub> falls below 0.34 V (approx. 30% of V<sub>REF</sub>). If this happens the boost converter and positive and negative charge pumps are disabled. Either V<sub>IN</sub> or EN must be cycled to recover normal operation.

### Undervoltage Protection (Positive Charge Pump)

During operation, if the output of the positive charge pump falls below its power good threshold for longer than 55ms, the TPS65155 will detect an undervoltage condition and turn itself off. V<sub>IN</sub> or EN must be cycled to recover normal operation.

### Negative Charge Pump Controller

The negative charge pump controller uses an external NPN transistor to regulate an external charge pump circuit. The controller is optimized for transistors having a DC gain ( $h_{FE}$ ) in the range 100 to 300. Regulation of the charge pump's output voltage is achieved by using the external transistor as a controlled current source whose output current depends on the voltage applied to the FBN pin. The higher the transistor's output current, the higher (i.e., more negative) the charge pump's output voltage.

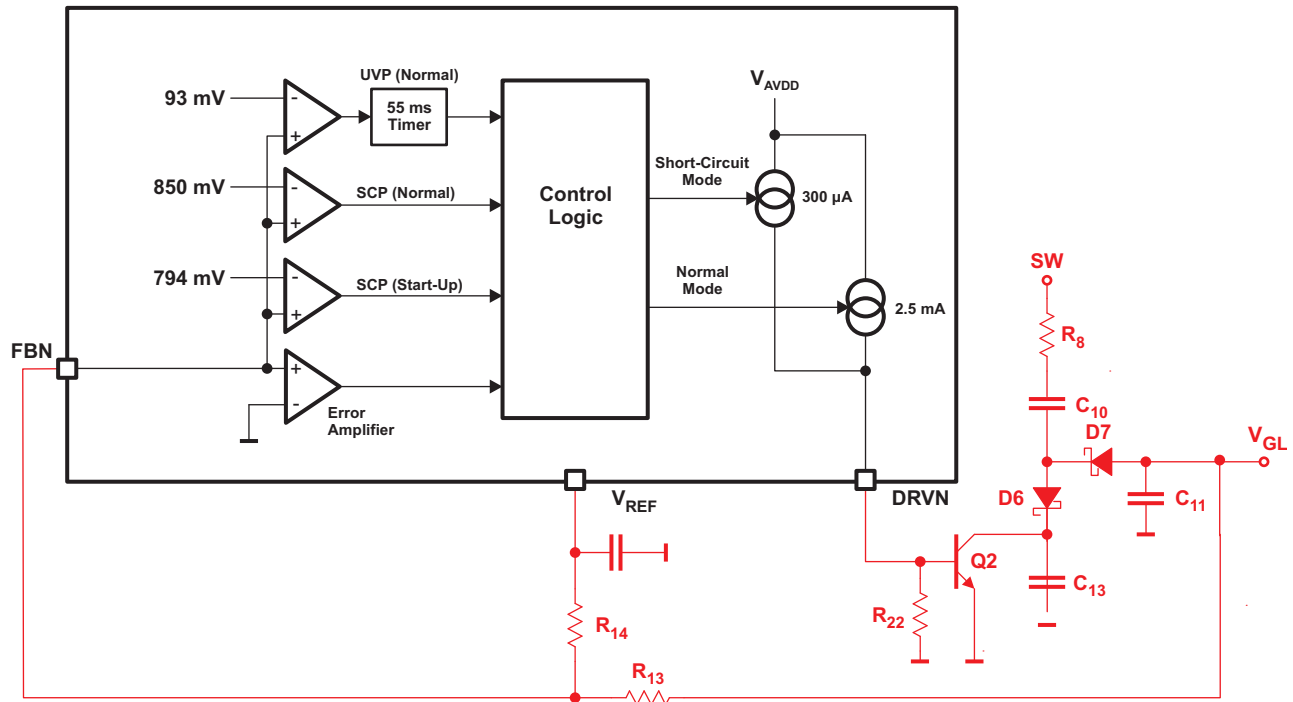

Figure 33. Negative Charge Pump Internal Block Diagram

### Setting the Output Voltage (Negative Charge Pump)

The negative charge pump's output voltage is programmed by a resistor divider according to Equation 18.

$$V_{GL} = -V_{REF} \times \frac{R_{13}}{R_{14}} \tag{18}$$

Rearranging Equation 18, the values of  $R_{13}$  and  $R_{14}$  can be easily calculated.

$$R_{13} = R_{14} \times \frac{|V_{GL}|}{V_{REF}} \tag{19}$$

Because of its limited output current capability, it is recommended to keep the current drawn from the VREF pin below 250  $\mu$ A to achieve best accuracy. A good approach is to use a value of at least 5.1 k $\Omega$  for the lower resistor ( $R_{14}$ ) and then select the upper resistor ( $R_{13}$ ) to set the desired output voltage. If a minimum charge pump load is desired (e.g. to improve regulation at very low load currents), it is best to add an additional resistor between  $V_{GL}$  and GND, rather than reduce the values of  $R_{13}$  and  $R_{14}$ .

Note that the maximum voltage in an application is determined by the boost converter's output voltage and the voltage drop across the diodes and NPN transistor. For a typical application in which the negative charge pump is configured as a voltage inverter, the maximum (i.e., most negative) output voltage is given by Equation 20.

$$V_{GL(MAX)} = -V_{AVDD} + (2 \times V_F) + V_{CE} \tag{20}$$

Where  $V_F$  is the forward voltage of each diode and  $V_{CE}$  is the collector-emitter voltage of the NPN transistor (recommended to be at least 1 V, to avoid transistor saturation).

### Selecting the NPN Transistor (Negative Charge Pump)

The NPN transistor used to regulate  $V_{GL}$  should have a DC gain ( $h_{FE}$ ) of at least 100 when its collector current is equal to the charge pump's output current. The transistor should also be able to withstand voltages up to  $V_{AVDD}$  across its collector-emitter ( $V_{CE}$ ).

The power dissipated in the transistor is given by Equation 21. The transistor must be able to dissipate this power without its junction becoming too hot. Note that the ability to dissipate power depends heavily on adequate PCB thermal design.

$$P_Q = [V_{AVDD} - (2 \times V_F) - |V_{GL}|] \times I_{GL} \quad (21)$$

Where  $I_{GL}$  is the *mean* (not RMS) output current drawn from the charge pump.

### Selecting the Diodes (Negative Charge Pump)

Small-signal diodes can be used for most low current applications (<50 mA) and higher rated diodes for higher power applications. The average current through the diode is equal to the output current, so that the power dissipated in the diode is given by Equation 22.

$$P_D = I_{GL} \times V_F \quad (22)$$

The peak current through the diode occurs during start-up and for a few cycles may be as high as a few amps. However, this condition typically lasts for <1 ms and can be tolerated by many diodes whose repetitive current rating is much lower. The diodes' reverse voltage rating should be equal to at least  $2 \times V_{AVDD}$ .

**Table 4. Negative Charge Pump Diode Selection**

PART NUMBER	$I_{AVG}$	$I_{PK}$	$V_R$	$V_F$	COMPONENT SUPPLIER
BAV99W	150 mA	1 A for 1 ms	75 V	1 V at 50 mA	NXP
BAT54S	200 mA	600 mA for 1 s	30 V	0.8 V at 100 mA	Fairchild Semiconductor
MBR0540	500 mA	5.5 A for 8 ms	40 V	0.51 at 500 mA	Fairchild Semiconductor

### Selecting the Capacitors (Negative Charge Pump)

For lowest output voltage ripple, low-ESR ceramic capacitors are recommended. The actual value is not critical and 1  $\mu$ F to 10  $\mu$ F is suitable for most applications. Larger capacitors provide better performance in applications where large load transient currents are present.

A flying capacitor in the range 100 nF to 1  $\mu$ F is suitable for most applications. Larger values experience a smaller voltage drop by the end of each switching cycle, and allow higher output voltages and/or currents to be achieved. Smaller values tend to be physically smaller and a bit cheaper.

A collector capacitor in the range 100 nF to 1  $\mu$ F is suitable for most applications. Larger values are more suitable for high current applications but can affect stability if they are too big.

### Short-Circuit Protection (Negative Charge Pump)

During start-up the negative charge pump limits the current available from  $V_{GL}$  until  $V_{FBN}$  is less than 794 mV. If  $V_{FBN}$  is still higher than 794 mV after  $\approx 20$  ms<sup>(1)</sup>, the boost converter, and positive and negative charge pumps are disabled. Either  $V_{IN}$  or EN must be cycled to recover normal operation.

During normal operation (i.e., once the negative charge pump has reached its power good threshold), short circuits are detected if  $V_{FBN}$  rises above 850 mV. If this happens, the boost converter, and positive and negative charge pumps are disabled. Either  $V_{IN}$  or EN must be cycled to recover normal operation.

### Undervoltage Protection (Negative Charge Pump)

During operation, if the output of the negative charge pump falls below its power good threshold for longer than 55ms, the TPS65155 will detect an undervoltage condition and turn itself off.  $V_{IN}$  or EN must be cycled to recover normal operation.

(1) Actually 10ms after the boost converter's power good.

## Reset Generator ( $\overline{\text{XAO}}$ )

The TPS65155 generates an open-drain reset signal that can be used to disable the T-CON during power-down. The  $\overline{\text{XAO}}$  signal is pulled low when  $V_{\text{DET}} < V_{\text{REF}}$  and is high impedance when  $V_{\text{DET}} > V_{\text{REF}}$  (+ hysteresis). The reset generator is not disabled when  $V_{\text{IN}}$  falls below the UVLO threshold, and continues to function down to very low values of  $V_{\text{IN}}$ .

## I<sup>2</sup>C Interface

The TPS65155 has an I<sup>2</sup>C serial interface for internal test purpose. Both the SCL and SDA need be pulled to  $V_{\text{IN}}$ .

## Level Shifters

The TPS65155 contains six level shifter channels (see Figure 34). Each channel features a logic-level input stage and a high-level output stage powered from  $V_{\text{GH}}$  and  $V_{\text{GL}}$ . The output stages are capable of generating high peak currents to drive the capacitive loads typically present in an LCD panel. Because the capacitive load typically connected to the STV and RESET channels is relatively small, the peak current available from these two channels is slightly lower than that available from the CLK channels.

During power-up, the level shifter outputs track  $V_{\text{GL}}$ . During power-down, the level shifter outputs track  $V_{\text{GH}}$ . Power-up and power-down conditions are determined by the  $V_{\text{DET}}$  threshold of the panel discharge function, which also controls the level shifter channels during power-up and power-down.

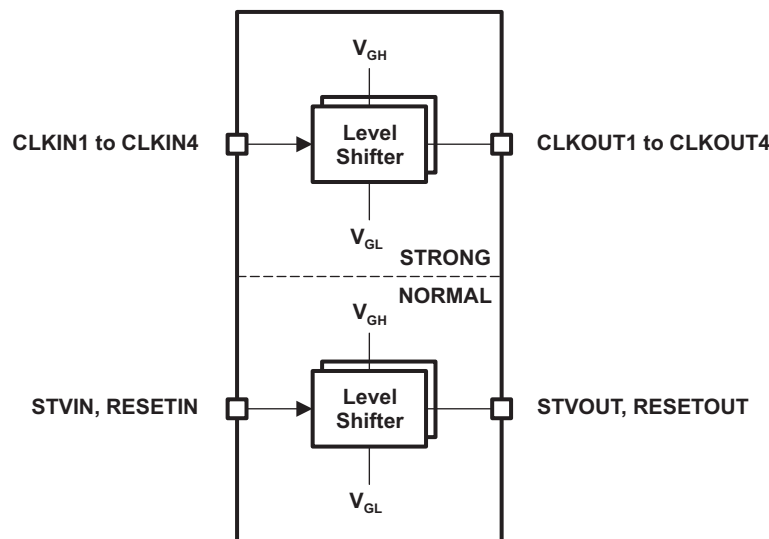

Figure 34. Level Shifter Block Diagram

## Power Supply Sequencing (Boost and Charge Pumps)

- When  $V_{\text{IN}} < V_{\text{UVLO}}$ , all functions are disabled.<sup>(2)</sup>
- When  $V_{\text{IN}} > V_{\text{UVLO}}$ , all functions are disabled if EN is low.
- When  $V_{\text{IN}} > V_{\text{UVLO}}$  and EN goes high, the boost converter and negative charge pump are enabled first. When the output of the boost converter reaches its power good threshold, the positive charge pump is enabled.
- If EN goes low, all functions are disabled.

## Power Supply Sequencing (Level Shifters)

- During power-up, when  $V_{\text{DET}}$  is below its input threshold, the level shifter outputs track  $V_{\text{GL}}$ .<sup>(3)</sup>
- During normal operation, when  $V_{\text{DET}}$  is above its input threshold, the level shifter outputs follow their inputs.
- During power-down, when  $V_{\text{DET}}$  falls below its input threshold, the level shifter outputs track  $V_{\text{GH}}$ .

(2) The level shifter discharge function continues to function for as long as there is sufficient operating voltage on  $V_{\text{GH}}$  and  $V_{\text{GL}}$ .

(3) The level shifter discharge function continues to function for as long as there is sufficient operating voltage on  $V_{\text{GH}}$  and  $V_{\text{GL}}$ .

### Power Supply Sequencing ( $\overline{\text{XAO}}$ )

- During power-up, when  $V_{\text{DET}}$  is still below its input threshold,  $\overline{\text{XAO}}$  is pulled low.
- During normal operation, when  $V_{\text{DET}}$  is above its input threshold,  $\overline{\text{XAO}}$  is high impedance.
- During power-down, when  $V_{\text{DET}}$  falls below its input threshold,  $\overline{\text{XAO}}$  is pulled low.

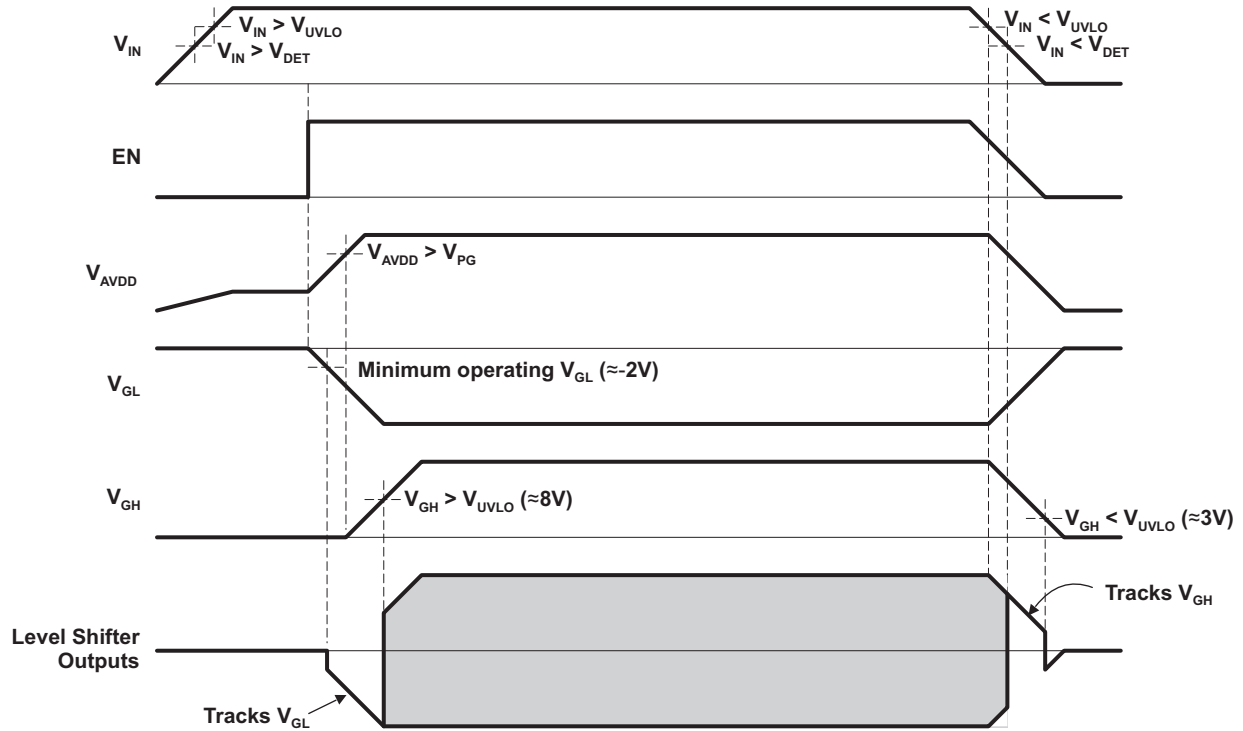

Figure 35. Power Supply Sequencing Using EN Pin,  $V_{\text{DET}} < V_{\text{UVLO}}$

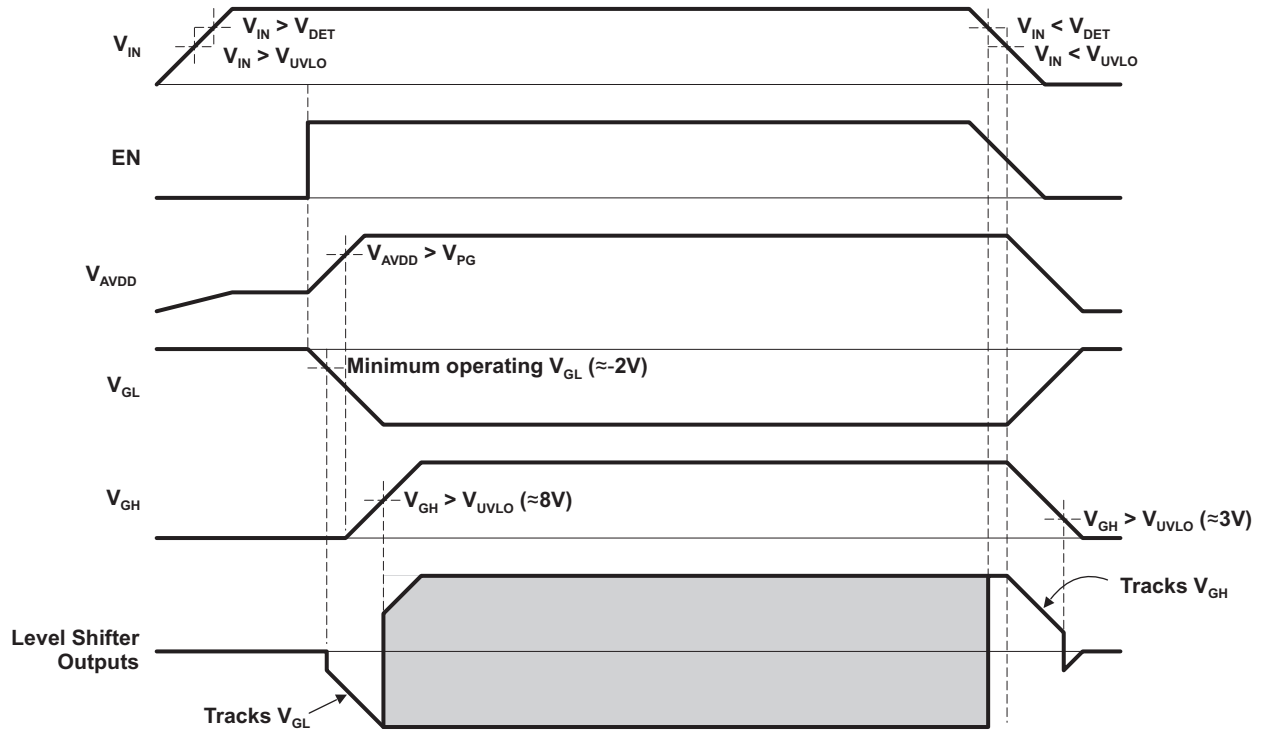

Figure 36. Power Supply Sequencing Using EN Pin,  $V_{DET} > V_{UVLO}$

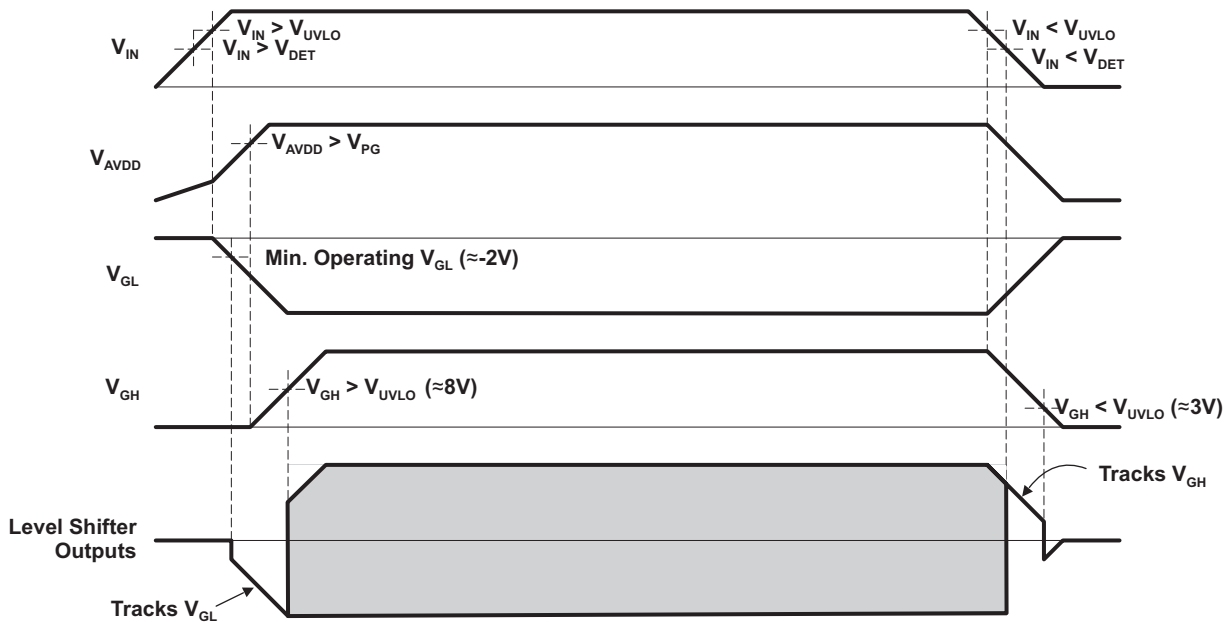

Figure 37. Power Supply Sequencing with EN Pin Tied to  $V_{IN}$ ,  $V_{DET} < V_{UVLO}$

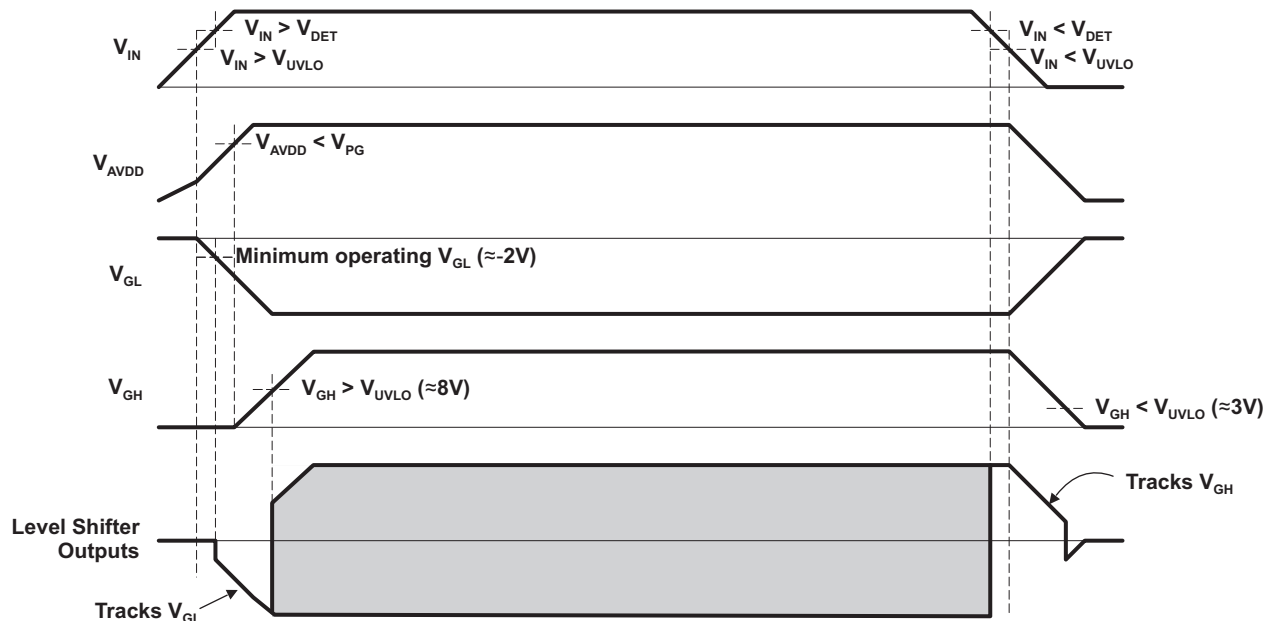

Figure 38. Power Supply Sequencing with EN Pin Tied to  $V_{IN}$ ,  $V_{DET} > V_{UVLO}$

## Undervoltage Lockout

The TPS65155 features an undervoltage lockout (UVLO) function that disables the LCD bias functions if the supply voltage ( $V_{IN}$ ) is below the minimum needed for correct operation ( $V_{UVLO}$ ).

## Thermal Shutdown

A thermal shutdown function automatically disables all LCD bias functions if the device's junction temperature exceeds the safe maximum. The device automatically starts operating again once it has cooled down.



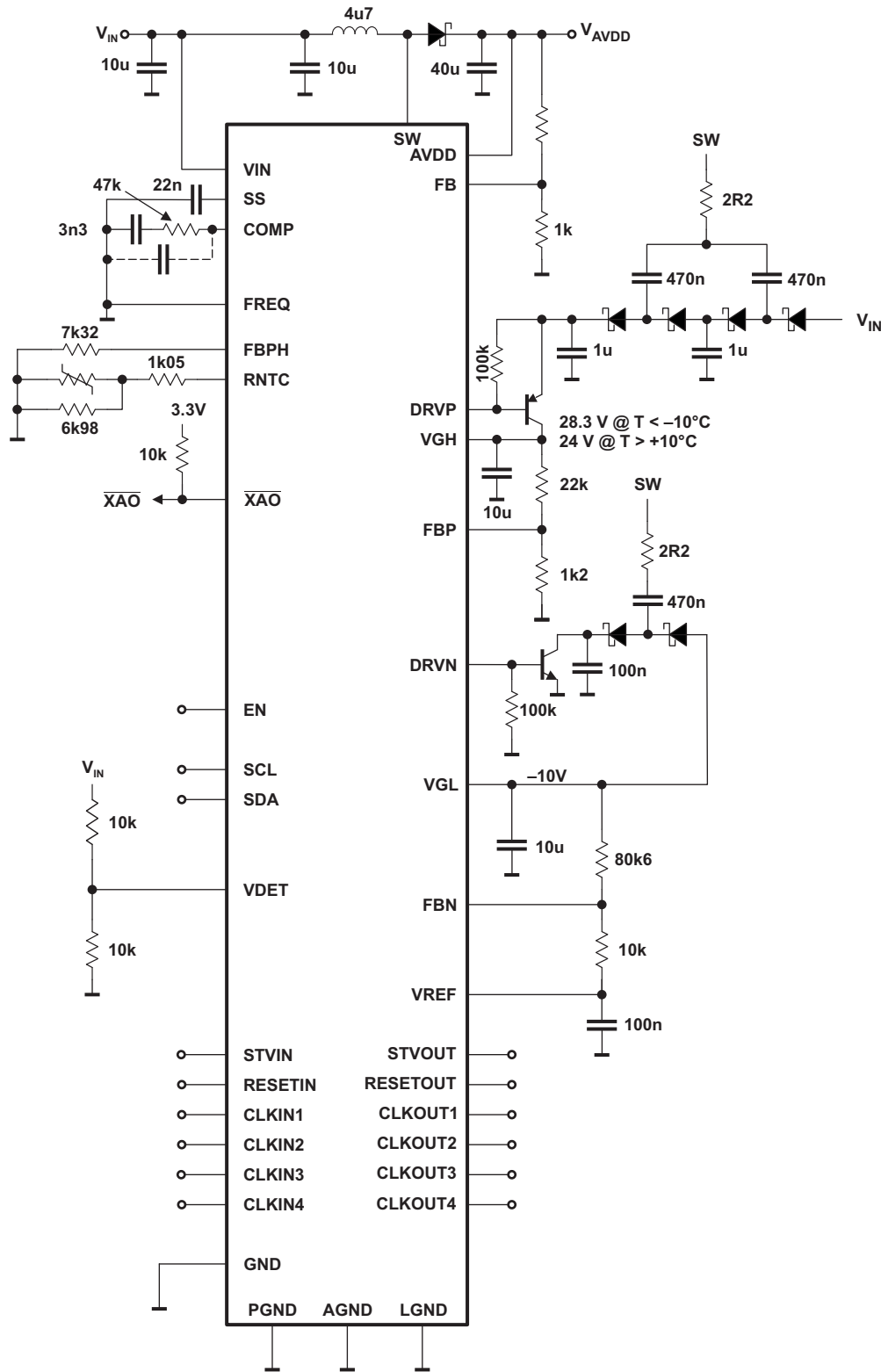

Figure 40. Typical Application Circuit Using Positive Charge Pump in  $\times 2.5$  Configuration

**PACKAGING INFORMATION**

Orderable Device	Status <sup>(1)</sup>	Package Type	Package Drawing	Pins	Package Qty	Eco Plan <sup>(2)</sup>	Lead/ Ball Finish	MSL Peak Temp <sup>(3)</sup>	Samples (Requires Login)
TPS65155RKPR	PREVIEW	VQFN	RKP	40	3000	Green (RoHS & no Sb/Br)	CU NIPDAU	Level-2-260C-1 YEAR	

<sup>(1)</sup> The marketing status values are defined as follows:

**ACTIVE:** Product device recommended for new designs.

**LIFEBUY:** TI has announced that the device will be discontinued, and a lifetime-buy period is in effect.

**NRND:** Not recommended for new designs. Device is in production to support existing customers, but TI does not recommend using this part in a new design.

**PREVIEW:** Device has been announced but is not in production. Samples may or may not be available.

**OBSOLETE:** TI has discontinued the production of the device.

<sup>(2)</sup> Eco Plan - The planned eco-friendly classification: Pb-Free (RoHS), Pb-Free (RoHS Exempt), or Green (RoHS & no Sb/Br) - please check <http://www.ti.com/productcontent> for the latest availability information and additional product content details.

**TBD:** The Pb-Free/Green conversion plan has not been defined.

**Pb-Free (RoHS):** TI's terms "Lead-Free" or "Pb-Free" mean semiconductor products that are compatible with the current RoHS requirements for all 6 substances, including the requirement that lead not exceed 0.1% by weight in homogeneous materials. Where designed to be soldered at high temperatures, TI Pb-Free products are suitable for use in specified lead-free processes.

**Pb-Free (RoHS Exempt):** This component has a RoHS exemption for either 1) lead-based flip-chip solder bumps used between the die and package, or 2) lead-based die adhesive used between the die and leadframe. The component is otherwise considered Pb-Free (RoHS compatible) as defined above.

**Green (RoHS & no Sb/Br):** TI defines "Green" to mean Pb-Free (RoHS compatible), and free of Bromine (Br) and Antimony (Sb) based flame retardants (Br or Sb do not exceed 0.1% by weight in homogeneous material)

<sup>(3)</sup> MSL, Peak Temp. -- The Moisture Sensitivity Level rating according to the JEDEC industry standard classifications, and peak solder temperature.

**Important Information and Disclaimer:** The information provided on this page represents TI's knowledge and belief as of the date that it is provided. TI bases its knowledge and belief on information provided by third parties, and makes no representation or warranty as to the accuracy of such information. Efforts are underway to better integrate information from third parties. TI has taken and continues to take reasonable steps to provide representative and accurate information but may not have conducted destructive testing or chemical analysis on incoming materials and chemicals. TI and TI suppliers consider certain information to be proprietary, and thus CAS numbers and other limited information may not be available for release.

In no event shall TI's liability arising out of such information exceed the total purchase price of the TI part(s) at issue in this document sold by TI to Customer on an annual basis.

RKP (S-PVQFN-N40)

PLASTIC QUAD FLATPACK NO-LEAD

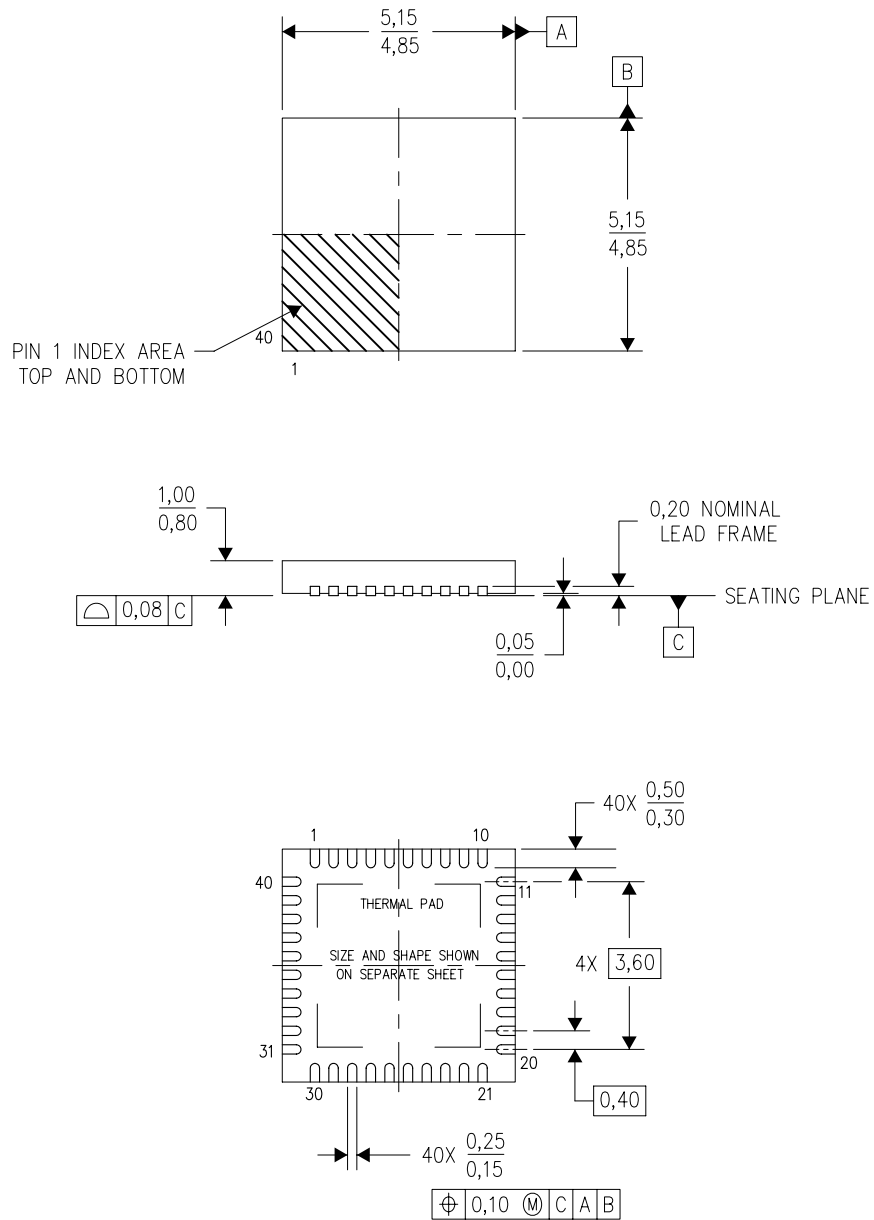

4211175/B 01/12

- NOTES:
- All linear dimensions are in millimeters. Dimensioning and tolerancing per ASME Y14.5M-1994.
  - This drawing is subject to change without notice.
  - QFN (Quad Flatpack No-Lead) Package configuration.
  - The package thermal pad must be soldered to the board for thermal and mechanical performance.
  - See the additional figure in the Product Data Sheet for details regarding the exposed thermal pad features and dimensions.

## IMPORTANT NOTICE

Texas Instruments Incorporated and its subsidiaries (TI) reserve the right to make corrections, modifications, enhancements, improvements, and other changes to its products and services at any time and to discontinue any product or service without notice. Customers should obtain the latest relevant information before placing orders and should verify that such information is current and complete. All products are sold subject to TI's terms and conditions of sale supplied at the time of order acknowledgment.

TI warrants performance of its hardware products to the specifications applicable at the time of sale in accordance with TI's standard warranty. Testing and other quality control techniques are used to the extent TI deems necessary to support this warranty. Except where mandated by government requirements, testing of all parameters of each product is not necessarily performed.

TI assumes no liability for applications assistance or customer product design. Customers are responsible for their products and applications using TI components. To minimize the risks associated with customer products and applications, customers should provide adequate design and operating safeguards.

TI does not warrant or represent that any license, either express or implied, is granted under any TI patent right, copyright, mask work right, or other TI intellectual property right relating to any combination, machine, or process in which TI products or services are used. Information published by TI regarding third-party products or services does not constitute a license from TI to use such products or services or a warranty or endorsement thereof. Use of such information may require a license from a third party under the patents or other intellectual property of the third party, or a license from TI under the patents or other intellectual property of TI.

Reproduction of TI information in TI data books or data sheets is permissible only if reproduction is without alteration and is accompanied by all associated warranties, conditions, limitations, and notices. Reproduction of this information with alteration is an unfair and deceptive business practice. TI is not responsible or liable for such altered documentation. Information of third parties may be subject to additional restrictions.

Resale of TI products or services with statements different from or beyond the parameters stated by TI for that product or service voids all express and any implied warranties for the associated TI product or service and is an unfair and deceptive business practice. TI is not responsible or liable for any such statements.

TI products are not authorized for use in safety-critical applications (such as life support) where a failure of the TI product would reasonably be expected to cause severe personal injury or death, unless officers of the parties have executed an agreement specifically governing such use. Buyers represent that they have all necessary expertise in the safety and regulatory ramifications of their applications, and acknowledge and agree that they are solely responsible for all legal, regulatory and safety-related requirements concerning their products and any use of TI products in such safety-critical applications, notwithstanding any applications-related information or support that may be provided by TI. Further, Buyers must fully indemnify TI and its representatives against any damages arising out of the use of TI products in such safety-critical applications.

TI products are neither designed nor intended for use in military/aerospace applications or environments unless the TI products are specifically designated by TI as military-grade or "enhanced plastic." Only products designated by TI as military-grade meet military specifications. Buyers acknowledge and agree that any such use of TI products which TI has not designated as military-grade is solely at the Buyer's risk, and that they are solely responsible for compliance with all legal and regulatory requirements in connection with such use.

TI products are neither designed nor intended for use in automotive applications or environments unless the specific TI products are designated by TI as compliant with ISO/TS 16949 requirements. Buyers acknowledge and agree that, if they use any non-designated products in automotive applications, TI will not be responsible for any failure to meet such requirements.

Following are URLs where you can obtain information on other Texas Instruments products and application solutions:

### Products

Audio	<a href="http://www.ti.com/audio">www.ti.com/audio</a>
Amplifiers	<a href="http://amplifier.ti.com">amplifier.ti.com</a>
Data Converters	<a href="http://dataconverter.ti.com">dataconverter.ti.com</a>
DLP® Products	<a href="http://www.dlp.com">www.dlp.com</a>
DSP	<a href="http://dsp.ti.com">dsp.ti.com</a>
Clocks and Timers	<a href="http://www.ti.com/clocks">www.ti.com/clocks</a>
Interface	<a href="http://interface.ti.com">interface.ti.com</a>
Logic	<a href="http://logic.ti.com">logic.ti.com</a>
Power Mgmt	<a href="http://power.ti.com">power.ti.com</a>
Microcontrollers	<a href="http://microcontroller.ti.com">microcontroller.ti.com</a>
RFID	<a href="http://www.ti-rfid.com">www.ti-rfid.com</a>
OMAP Mobile Processors	<a href="http://www.ti.com/omap">www.ti.com/omap</a>
Wireless Connectivity	<a href="http://www.ti.com/wirelessconnectivity">www.ti.com/wirelessconnectivity</a>

### Applications

Automotive and Transportation	<a href="http://www.ti.com/automotive">www.ti.com/automotive</a>
Communications and Telecom	<a href="http://www.ti.com/communications">www.ti.com/communications</a>
Computers and Peripherals	<a href="http://www.ti.com/computers">www.ti.com/computers</a>
Consumer Electronics	<a href="http://www.ti.com/consumer-apps">www.ti.com/consumer-apps</a>
Energy and Lighting	<a href="http://www.ti.com/energy">www.ti.com/energy</a>
Industrial	<a href="http://www.ti.com/industrial">www.ti.com/industrial</a>
Medical	<a href="http://www.ti.com/medical">www.ti.com/medical</a>
Security	<a href="http://www.ti.com/security">www.ti.com/security</a>
Space, Avionics and Defense	<a href="http://www.ti.com/space-avionics-defense">www.ti.com/space-avionics-defense</a>
Video and Imaging	<a href="http://www.ti.com/video">www.ti.com/video</a>

TI E2E Community Home Page

[e2e.ti.com](http://e2e.ti.com)

Mailing Address: Texas Instruments, Post Office Box 655303, Dallas, Texas 75265  
Copyright © 2012, Texas Instruments Incorporated